

CS 849C Lecture 6

1 Diodes

(1) Symbol and I-V Characteristic of Diode

A diode is a two-terminal active electronic device containing an anode and a cathode, and it is characterized by the ability to pass an electric current more easily from cathode to anode than from anode to cathode.

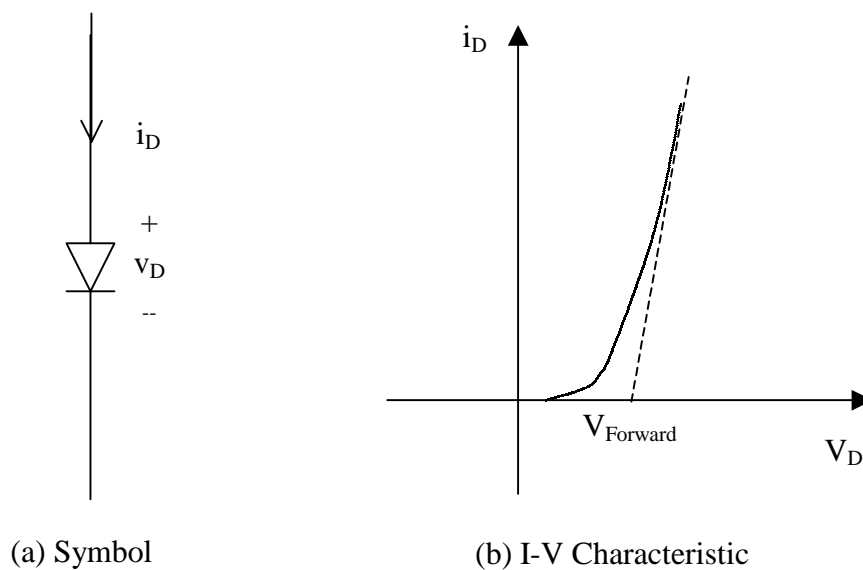
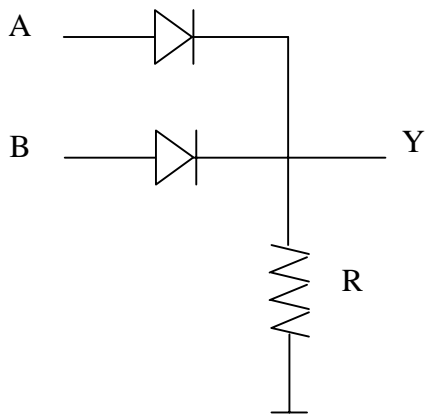

Figure 1 Symbol and I-V characteristic of Diode

Symbol of the diode is shown in figure 1-(a). V_D is the bias voltage across the diode, and i_D is the current through the diode. The diode I-V characteristic is shown in figure 1-(b). Here the dashed line indicates the ideal I-V characteristic and the solid line indicates a realistic I-V characteristic. Below forward voltage, current through the diode can be taken as zero, above forward voltage, current increases rapidly with the increase of voltage.

(2) Logical Implementation for Diodes

Given the basic I-V characteristic of diode, we can discuss a couple of structures that can implement logic functions. The first one is an “OR” gate.



(a) Schematic

A	B	Y
0	0	0
0	1	1
1	0	1
1	1	1

(b) Truth Table

Figure 2 Schematic and truth table for “OR” gate

In Figure 2-(a), A and B are the two inputs, and Y is the output. Resistor R is connected to ground. When A and B are both low, Y is low. If either A or B is high, because resistor R is much greater than the internal resistor of A and B, voltage across R is high, so output Y is high. The truth table is listed in figure 2-(b).

Next we introduce an “AND” gate which is shown in figure 3. Again, A and B are the inputs and Y is the output. The resistor is connected to V_{DD} .

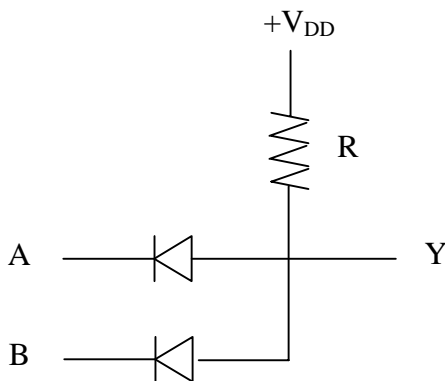

(a) Schematic

A	B	Y
0	0	0
0	1	0
1	0	0
1	1	1

(b) Truth Table

Figure 3 Schematic and truth table for “AND” gate

Here if A and B are both high, no current flows through resistor R, and the output Y is high. If A or B is low, the respective diode is turned on and there is a large voltage drop across R, so output Y is low. Let us discuss this structure in more detail.

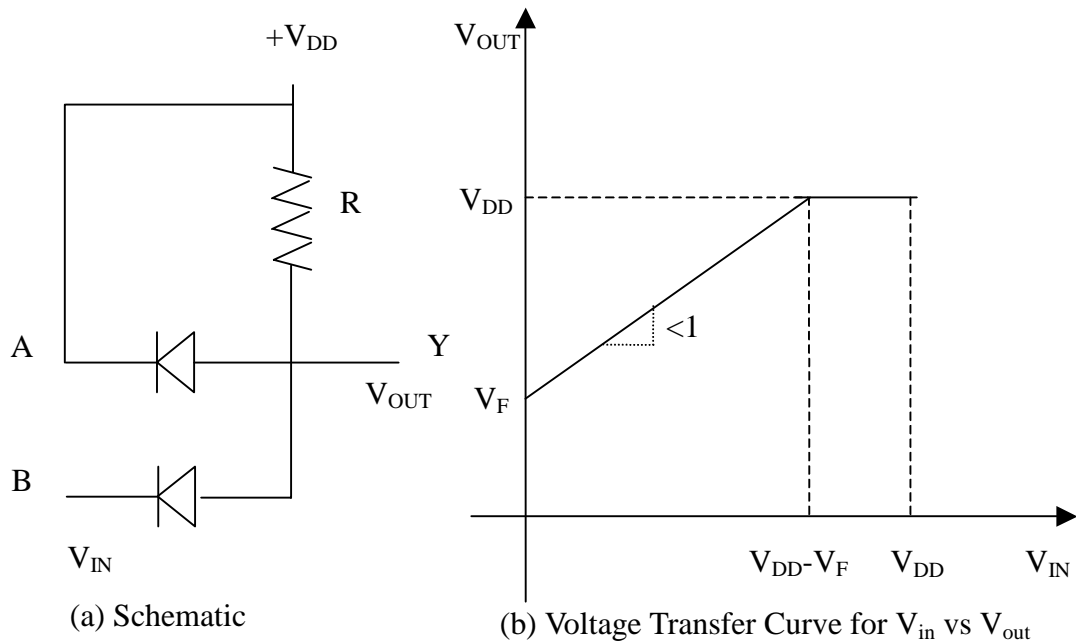

Figure 4 Detailed analysis of “AND” gate

In order to get the characteristic of transform function of V_{OUT} over V_{IN} , we set input A to V_{DD} and change the input voltage V_{IN} on input B. When V_{IN} is equal to V_{DD} , there is no current through resistor R, and output Y is equal to V_{DD} . Now we reduce V_{IN} . Nothing happens until V_{IN} reaches $V_{DD}-V_F$ (where V_F is the forward voltage of diodes). Then when V_{IN} continues to decrease, V_{OUT} decreases accordingly. At last when V_{IN} is zero, the curve intercepts Y axis at V_F .

(3) Disadvantages of Diode Circuits

Diode circuits have several disadvantages as listed below.

(1) We cannot implement inverting logic with diodes. The only option is to use other logic devices for inversion. (2) The I-V characteristic has low small signal gain in the transition region. (3) There is no isolation between input and output in these gates.

2 Resonant Tunneling Diode

Resonant tunneling diode is a device that has two tunneling Junctions. Its I-V characteristic shows negative differential resistance characteristic (NDR).

(1) Structure of RTD

Figure 5 shows the structure of RTD. Here the gray part is GaAs that has small band gap, and the white part is AlGaAs that has large band gap.

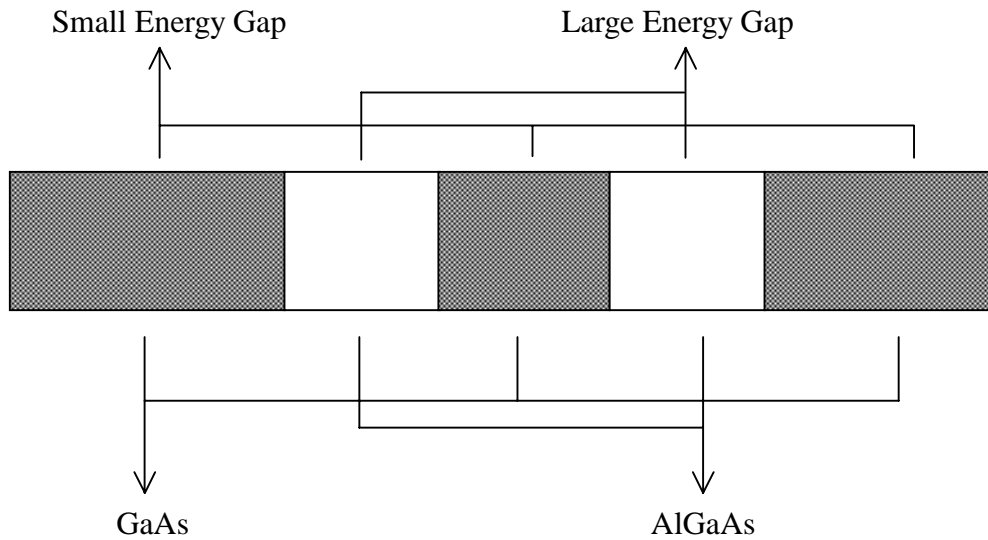

Figure 5 RTD Structure

(2) Energy Band Diagram of RTD

We show the energy band diagram of RTD in figure 6. From the figure we can see that RTD has thin well region and a thin barrier region. According to quantum mechanics, electrons can tunnel from outside into the well through barrier under suitable conditions.

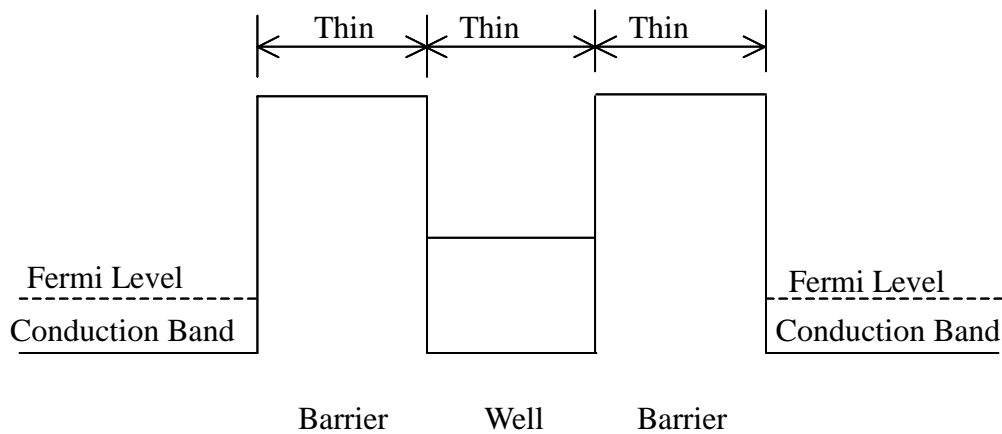

Figure 6 Energy band diagram of RTD

Without any voltage bias, the electron energy level in the well is higher than fermi levels of both sides. So, no electron in the conduction band can tunnel to the well, and there is no current.

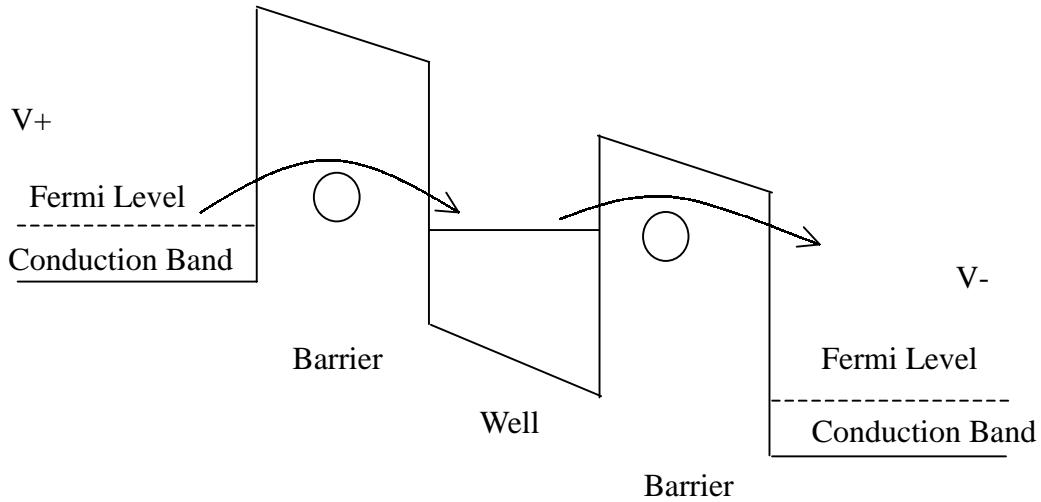

Figure 7 Energy band diagram of RTD with small bias voltage

Now we apply a bias voltage across the RTD. The energy level diagram changes as shown in figure 7. Because of the bias voltage, energy level on the left becomes higher. Now some electrons in the left can tunnel into the well. After that they can continue to tunnel out to the right. Current from left to right increases due to tunneling.

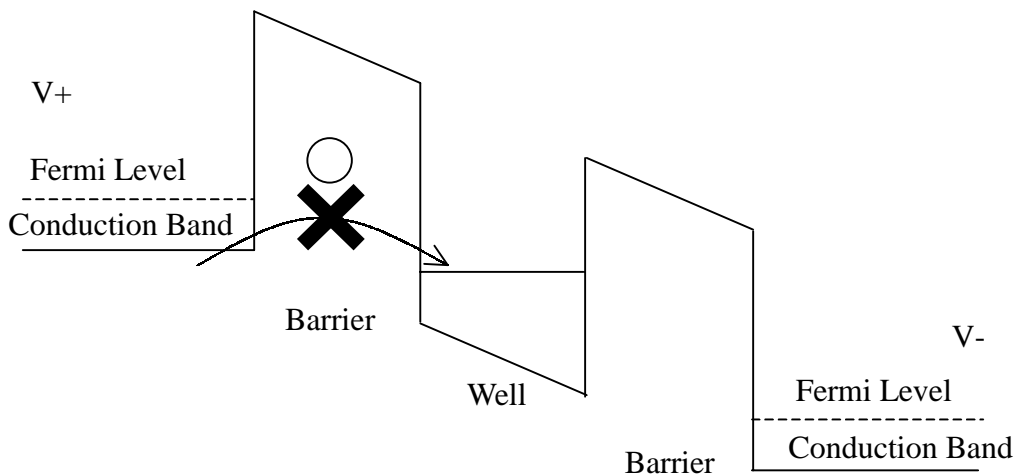

Figure 8 Energy band diagram of RTD with large bias voltage

Now let's continue to increase the bias voltage. The energy level on the left continues to increase. Though electrons in well region can tunnel out to the right side by inelastic tunneling, no electrons can tunnel from left to the well region now. As a result, current begins to decrease, and we get the NDR region in the I-V curve.

(3) I-V Characteristic for RTD

From the analysis above, we can get the I-V characteristic for RTD as is shown in figure 9.

First, because of the tunneling of electrons, current through RTD increases with the increase of V_D . Then when V_D continues to increase, after some point (I_{ON}), no electrons on the left can tunnel into the well, and current begins to decrease. If we keep increasing V_D , due to thermal mechanisms, current begins to increase once again.

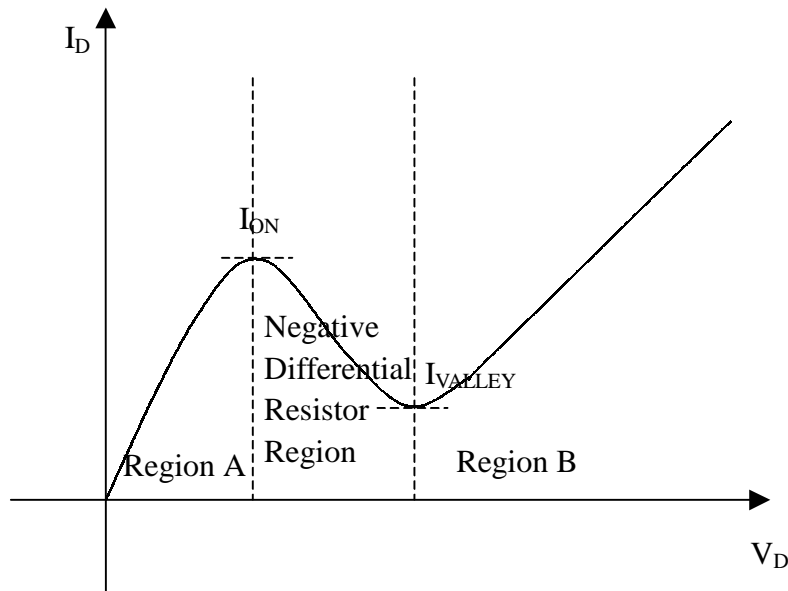

Figure 9 I-V characteristic of resonant tunneling diode

In figure 9, I_{ON} is the peak current generated by the tunneling of electrons. I_{VALLEY} is the valley current due to the decrease in tunneling. Large ratio of I_{ON}/I_{VALLEY} is desirable. This is because large ratio means large gain for the negative differential resistor region. Secondly, large ratio often implies small I_{VALLEY} . I_{VALLEY} is usually the leakage current. So decreasing I_{VALLEY} leads to decreasing power dissipation.

(4) Logical Implementation for RTD

As an example, an “xor” circuit which uses a resonant tunneling diode and an ordinary diode is analyzed below. The schematic of the circuit is shown in figure 10.

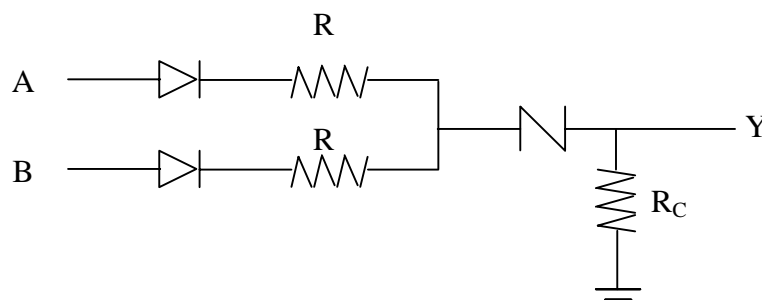

Figure 10 “XOR” Circuit Schematic

Here input A and B are both connected to ordinary diodes, which in turn, are connected to resistors. Then both of them are connected to a resonant tunneling diode, which is connected to a resistor R_C .

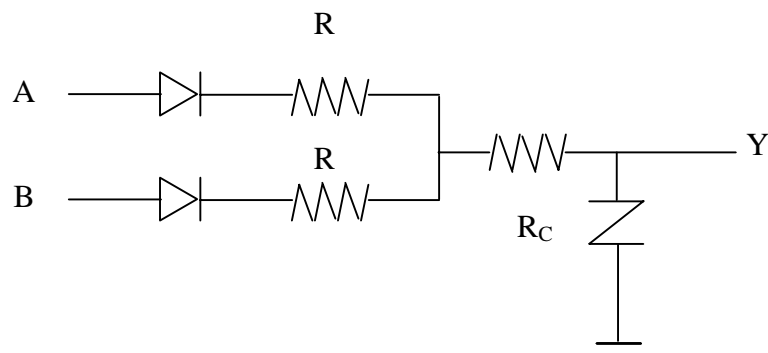

Figure 11 Equivalent Circuit for “XOR”

For purposes of calculating voltage across the resonant tunneling device, the order of connecting the RTD and resistor R_C does not matter. So we can analyze the equivalent circuit shown in figure 11. RTD exchanges its place with resistor R_C . This does not change the voltage across RTD.

Now we will analyze the characteristic of the circuit with different inputs. Firstly, we will analyze the situation when A is low (0 volts) and B is high (V_{DD}).

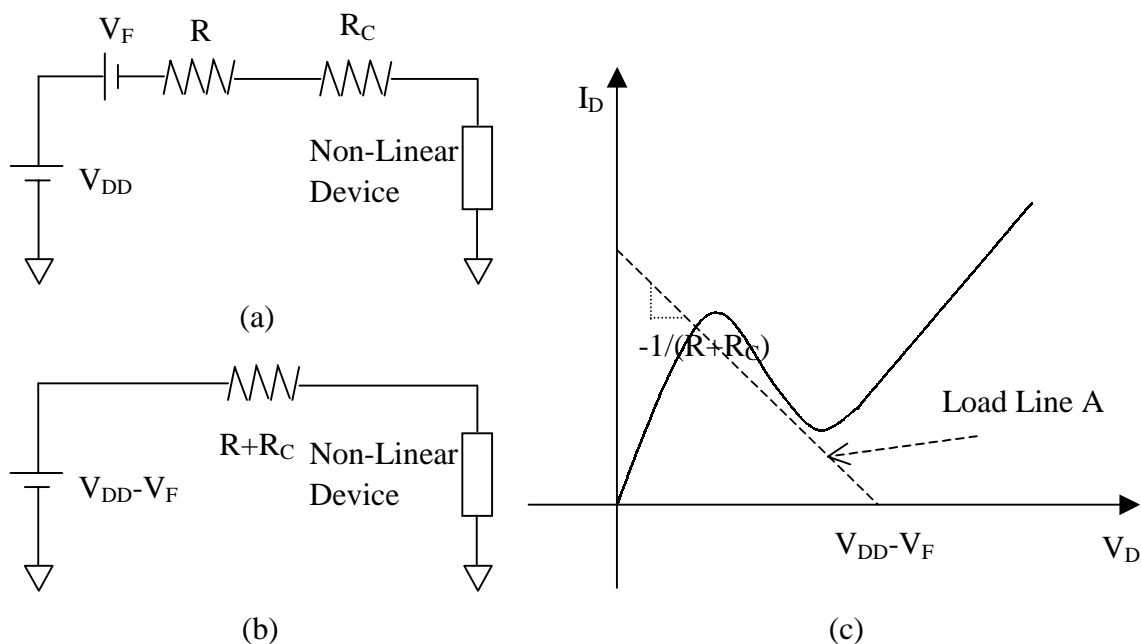

Figure 12 Circuit Analysis with A is low and B is high

Because A is zero, diode connected with A is turned off and can be removed from the circuit. B is V_{DD} , so diode connected with B is turned on. We can get the equivalent circuit as shown in figure 12-(a). V_F is the turn on voltage of an ordinary diode. Merging voltage sources and resistors that are connected in series, we get the reduced equivalent circuit shown in figure 12-(b). Now we can draw load line of the

circuit which is shown in figure 12-(c). Load line intercepts axis X at $V_{DD}-V_F$ and its slope is equal to $-1/(R+R_C)$. We can find that in this case voltage across RTD is low, so output Y is high. By the same method we can easily deduce that when A is high and B is low, output Y becomes high.

In the second step we set both A and B to high. In this case, both the diodes are turned on.

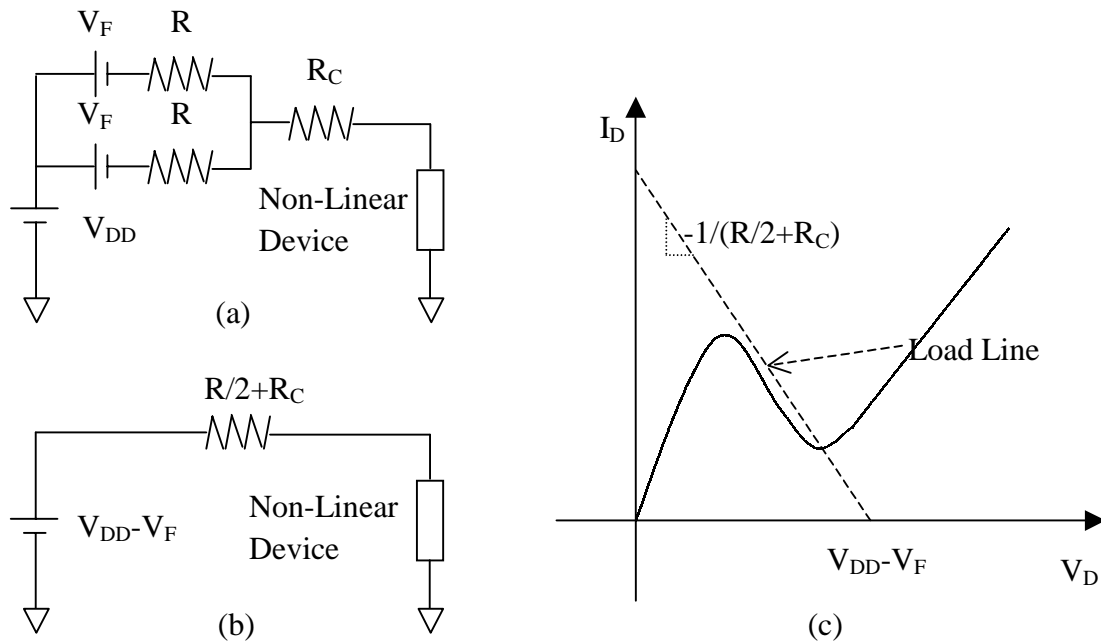

Figure 13 Circuit Analysis with both A and B are high

We get the equivalent circuit for this situation as shown in figure 13-(a). The equivalent voltage source is still $V_{DD}-V_F$ but the resistor connected to it becomes $R/2+R_C$. Load line is shown in figure 13-(c). It has a slope of $-1/(R/2+R_C)$. From the figure we can see that the voltage drop across RTD is high, so output Y becomes low.

The third step is to set both A and B to low, in which case there is no current through R_C . It is obvious that output Y becomes low.

A	B	Y
0	0	0
0	1	1
1	0	1
1	1	0

⇒ $Y=A \text{ XOR } B$

Figure 14 Truth table for the “XOR” circuit

From the analysis above, we can get the truth table as shown in figure 14. We should note that the low output voltage is often greater than zero and the high output is smaller than V_{DD} .

Another example we will show here is an RTD latch. It is composed of two RTDs connected in series.

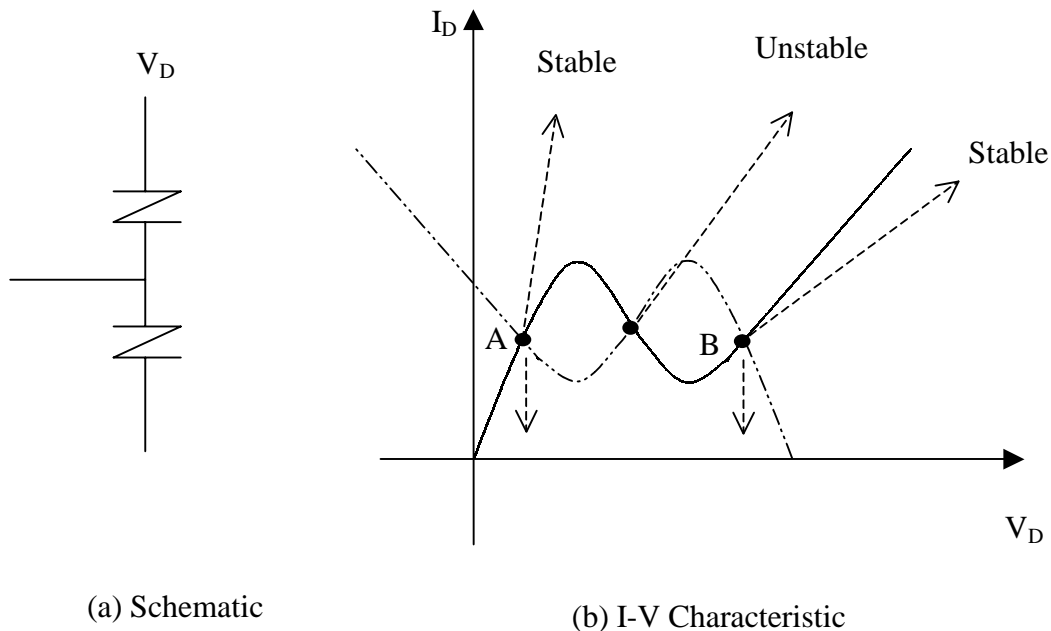

Figure 15 RTD Latch

The schematic of the RTD latch is shown in figure 15-(a). Here V_D is the bias voltage.

In order to get load line characteristic, we first draw the I-V curve for one RTD and then flip and shift the I-V curve for the other RTD and draw it in the same figure as shown in figure 15-(b). These two I-V curves intersect at 3 points. One is located at low voltage, one is located at high voltage and another is located at middle voltage. The middle one is not stable and the other two are stable.

Another thing we want to talk about the RTD latch here is power dissipation. In order to lower the circuit's power dissipation, we can lower the intersecting points A and B. But by doing so, we also lower the driving capability of the output of the circuit and the speed of the circuit. So there is a tradeoff between power dissipation and speed.

3. Nanotube FET

Carbon nanotubes are one-dimensional nano structures with electrical properties that can be used for applications in nanoelectronics. Recent researches find that they can be used as the channel of nanotube field-effect transistors.

Figure 16-(a) is AFM image of an intramolecular logic gate. A single nanotube bundle is positioned over the gold electrodes to produce two p-type CNTFETs in

series. The device is covered by PMMA and a window is opened by e-beam lithography to expose part of the nanotube. Potassium is then deposited through this window to produce an n-CNTFET, while the other CNTFET remains p-type. Figure 16-(b) is the characteristic of the resulting intramolecular voltage inverter

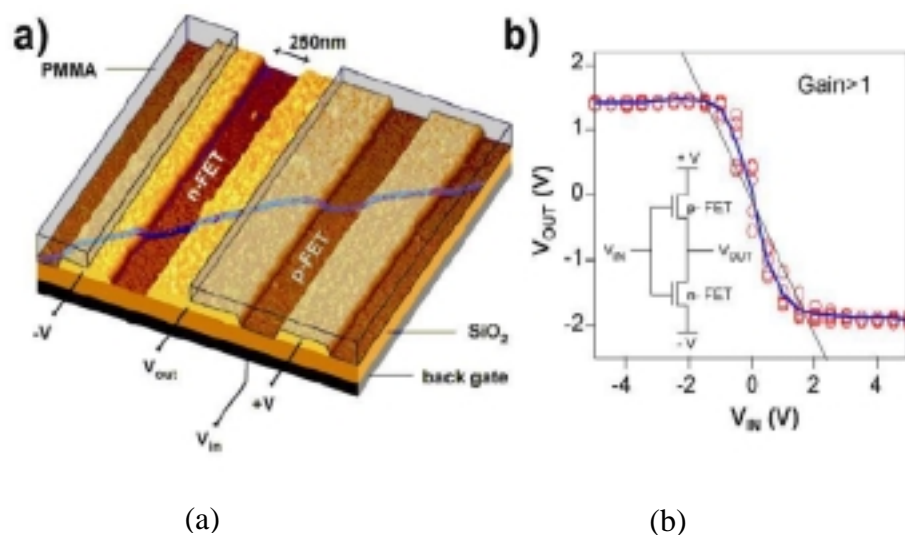

Figure 16 Nanotube FET

4. A Molecular Electronic Device

Here we introduce an electronic device that uses a molecule containing a nitroamine redox center as shown in figure 17.

Typical I-V characteristics of a Au-(1c)-Au device at 60 K are shown in figure 17-(b). The peak current density for this device was $.53 \text{ A/cm}^2$, the NDR was 2380 mohm/cm^2 , and the peak-to-valley ratio (PVR) was 1030:1. This device exhibits a robust and large NDR.

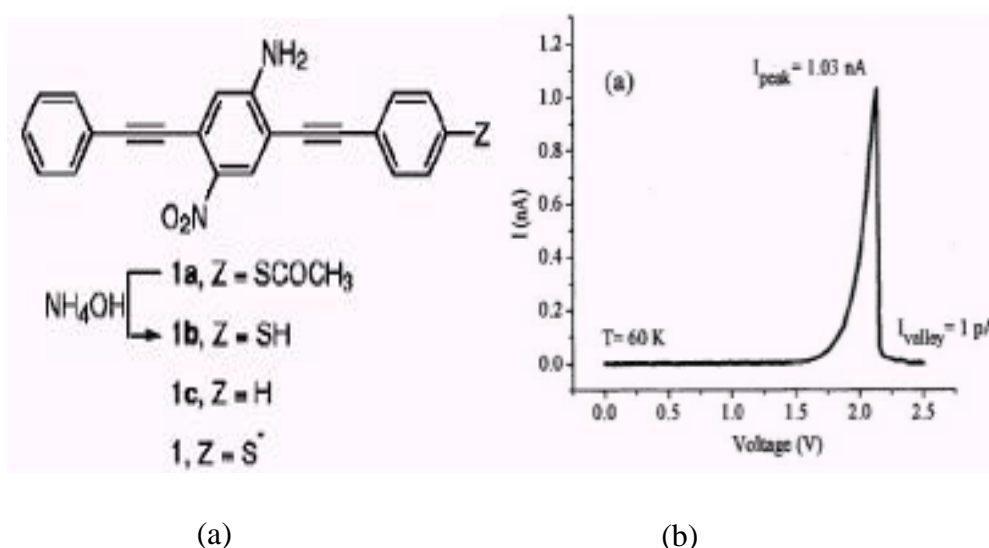

Figure 17 A Molecular Electronic Device