

Adaptive Fuzzy Throttle Control for an All Terrain Vehicle

Ashitey Trebi-Ollennu, and John M. Dolan

Carnegie Mellon University, Institute for Complex Engineered Systems

5000 Forbes Avenue, Pittsburgh, PA, 15213, USA

ashitey@cs.cmu.edu

1 Abstract

This paper describes an adaptive fuzzy throttle control for an All Terrain Vehicle (ATV) powered by internal combustion engine. The design objective is to provide smooth throttle movement, zero steady-state speed error, and to maintain a selected vehicle speed over varying road slopes for a 2MPH to 30MPH speed range. Unlike modern production vehicles which have microprocessor-based engine management systems, the ATV's engine is mechanically controlled via a carburetor. A complete mathematical model of the engine is not available making it very difficult to apply convention control techniques. Using experience and data collected from extensive experiments conducted on the ATV throttle mechanism, an adaptive fuzzy throttle control algorithm is designed. A candidate Lyapunov function is employed in the adaptive law synthesis to ensure convergence. Experimental results are presented showing the effectiveness of the control algorithm at speeds below 2.74MPH (1.2m/s).

2 Introduction

In this paper, we present an adaptive fuzzy speed control design for a throttle-regulated internal combustion engine on an All Terrain Vehicle (ATV). The ATV is one of several mobile platforms used in the CyberScout project, at Carnegie Mellon University's, Institute for Complex Engineered Systems. The CyberScout project aims to develop distributed mobile robotic technologies that will extend the sphere of awareness and mobility of small military units while exploring issues of command and control, task decomposition, multi-agent collaboration, efficient perception algorithms, and sensor fusion.

Two Unmanned Ground Vehicles (UGV) have been built by retrofitting two Polaris Sportsman 500 ATVs (named Lewis and Clark, after the famous explorers), automating their throttle, steering, braking, and gearing functions and giving them computation for control, navigation, sensing, and communication. The automatic steering, braking, and gearing functions are actuated hydraulically; an R/C servomotor placed in line with the throttle cable controls the throttle. A 2.5kW generator provides auxiliary power, primarily for the hydraulics. The computational architecture is two-tiered: locomotion control is performed by a PC/104, while planning, perception, and communications are performed by a laptop PC in concert with auxiliary perceptual processors. Navigational sensing is performed by 20-cm resolution NovAtel GPS; perceptual sensing is currently restricted to vision, which we are trying to exploit to the fullest due to its passive, unobtrusive nature; and communications with other platforms and with remote users are performed via wireless Ethernet.

The following capabilities have already been demonstrated: remote manual control of the ATV using various input devices (R/C joystick, laptop, wearable computer); autonomous GPS-based waypoint navigation; autonomous convoying based on visual tracking; and personnel/vehicle classification using vision. In this paper, one of the subsystems crucial to achieving complete

autonomy, the low-level vehicle speed control system is presented. Since the ATV is equipped with cameras for navigation it is essential that the vehicle move smoothly at speeds that will allow real-time processing of the images.

In the literature several authors have developed automobile speed control systems (cruise control). A brief review of the techniques employed will be outlined below. In (M. K. Liubakka 1993), an adaptive control structure is proposed for different vehicle lines with very little recalibration. Using slow adaptation and sensitivity-based gradient algorithms, the gains of a PI controller are adjusted to minimize a quadratic cost function. The cost function was formulated from experimental and simulation studies and was shown to improve the performance of all the tested vehicles over varying road terrain. In (Takahashi 1988) an automatic speed control system employing self-tuning fuzzy logic rules is outlined. The scheme uses fuzzy logic to tune the speed control characteristics of a vehicle to match individual drivers' preferences. This control scheme is also aimed at reducing the time required to determine the optimum control parameters for different vehicle lines. The key difference is that (Takahashi 1988) uses fuzzy logic to infer the particular driving habits of individual drivers and the results are used to vary the control characteristics when the vehicle is under cruise control. Simulation and experimental results are presented to demonstrate the effectiveness of the control scheme.

(Alexander G. Loukianov 1997) presented a robust stabilizing controller for an internal combustion engine with throttle driven by a DC motor. The control structure comprises of two loops; the Drive loop and Engine loop. Block control technique is employed in the Engine loop to linearise the engine dynamics. A high gain engine observer is used to estimate the load torque as well as the engine state vector. The output of the Engine loop forms the reference input (throttle plate angle) for the Drive loop. A generalized observer for nonlinear plants was utilized to estimate the drive state vector to realize the Drive loop. Sliding Mode control strategy is used in the Drive loop to provide fast and precise tracking of the throttle plate angle. Because of the fast Drive loop dynamics, it is possible to design the two loops independently. Excellent simulation results based on a six-cylinder engine were presented. Although the simulation results confirm the theoretical predictions, the practical application of the method is at present rather limited. Similarly (Byeong-Jo Lee 1993) described an engine throttle control for an experimental automobile using anticipatory band in a sliding phase plane. The throttle is actuated by pneumatic servo-system with two solenoid on-off valves to controlling the pressures in two pneumatic chambers separated by a diaphragm. An obvious solution to this control problem is to apply sliding mode control. However, in conventional sliding mode control technique a full-state measurement is required but is not available in this case. Also the on-off control limitations of pneumatic servo-system impedes the straightforward application of sliding mode control technique. Ideal sliding mode can only be obtained by infinite switching frequencies. However, infinite switching frequencies cannot general be implemented because of the existence of inherent delay, hysteresis etc in actuators and the pneumatic actuator is no exception. The authors therefore propose an anticipatory band to switch the control function before the sliding phase is reached. The anticipatory band is shown to stabilize the system and in reducing output chattering in experimental results presented. To further demonstrate the advantages of the proposed control scheme, it was compared to a bang-bang and PI controller on the same experimental vehicle. Results presented showed that the anticipatory band controller provided a much better performance, with the least amount of chatter and most accurate tracking.

Also (Martin Sommerville 1998) presented a switching control scheme for a pneumatic throttle actuator. The throttle actuator is a pneumatic cylinder, which generates a force proportional to the ratio of the cylinder's internal air pressure to atmosphere pressure. The internal air pressure is controlled using two valves that allow either the engine's intake manifold pressure or atmosphere

pressure. The actuator's internal pressure is controlled using three solenoid-activated valves, which control the airflow in and out of the pneumatic cylinder. Two linear models were developed for the throttle actuator, throttle cable, and throttle plate system for when the vent valve is opened and the other when in full vacuum mode. Using experimental data from a pneumatic throttle actuator on a 1992 Honda-Accord station wagon. In between two sampling times either full vacuum or full vent can be applied, therefore the authors used sliding mode technique in their control system design. The sliding surface is defined in terms of throttle plate angle error since throttle plate angle is measurable. However the signal is reported to be very noisy therefore it was not possible to approximate the numerical derivative of the throttle plate angle from the data, which is required in the sliding mode control design. Therefore a modified asymptotic observer was employed to estimate it. Experimental results are presented showing the desired, measured and estimated throttle angle when several input references are supplied to the controller. The observer is shown to filter out most of the measured signal noise at the expense of tracking error at very low and relative high throttle angles. The proposed control scheme seems to work best at throttle angles that correspond to normal operating highway speeds.

Although some of the reviewed automatic speed controllers in the literature have been implemented on production vehicles, the control techniques are not directly applicable to the ATV throttle control problem. First, the ATV's engine is mechanically controlled via a carburetor, unlike most production vehicles, which have microprocessor-based engine management systems which guarantee maximum engine efficiency and horsepower. Second, the ATV carburetor clearance makes it difficult to incorporate a sensor to measure the throttle plate angle, which is required in virtually all the automotive speed controllers in the literature. Third, and importantly, although most modern automobiles are equipped with automatic speed control (cruise control) they are generally recommend to be used at speeds greater than 30MPH. At speeds below 30MPH most internal combustion engines exhibit considerable torque fluctuations a highly nonlinear phenomenon which results in considerable variation in engine speed and crankshaft angular speed. This makes it extremely challenging to design an effective control algorithm for speeds below 30MPH. Finally, the ATV throttle is actuated via R/C servo instead of a pneumatic actuator, the preferred actuator in most production vehicles. Although the R/C servo setup has the potential to provide faster and more accurate throttle plate control, it provides no explicit feedback of the servo's angular position.

We propose an adaptive fuzzy throttle control scheme for the ATV. Fuzzy rules are formulated from extensive experiments conducted by human operators and quantitative data. The organization of the rest of the paper is as follows. In section (3) a brief overview of the ATV's throttle and power train systems is presented. The engine mathematical model is presented in section (4). Section (5) outlines the design objectives, section (6) presents the control law formulation and results, and section (7) gives conclusions.

3 Overview of ATV Throttle Actuation and Power Train System

The ATV is a Polaris Sportsman 500 equipped with a 4-stroke, liquid-cooled engine with a 34mm Mikuni carburetor. The primary input for controlling the speed for an internal combustion engine vehicle is the closing and opening of the throttle plate. The Polaris Sportsman 500 is equipped with a Mikuni CV carburetor. The carburetor incorporates a mechanically operated throttle plate and a vacuum-controlled slide valve as shown in Figure 1.

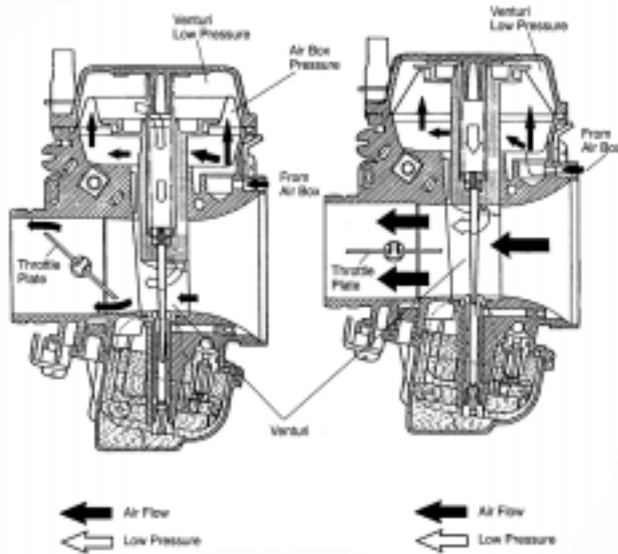

Figure 1 Diagram of Mikuni CV Carburetor (Manual 1995)

Because the throttle plate opening regulates the torque generated by the engine, accurate control of the opening is essential for effective speed control. Figure 2 depicts the ATV's retrofitted throttle control setup. A Futaba R/C servomotor has been introduced in the cable connecting the throttle lever to the throttle plate. This preserves a rider's ability to manually control the throttle using the lever, while allowing autonomous control via the R/C servo.

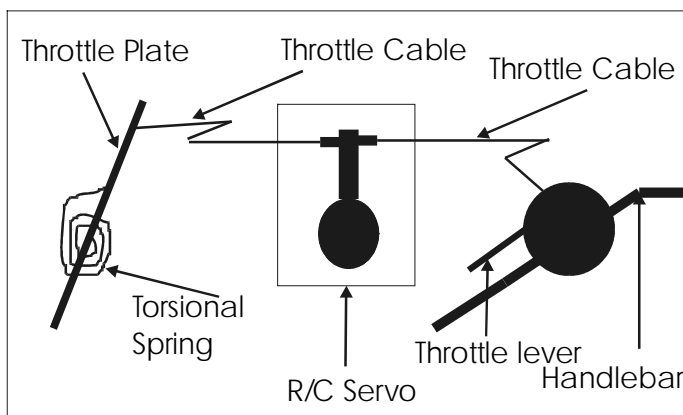

Figure 2 Modified Throttle System including throttle actuator, ATV handle bar and throttle plate

The throttle plate setup incorporates a torsional spring, which applies a closing torque on the throttle plate sufficient to back drive the servo to idle throttle position when power is turned off. The choice of an R/C servo for throttle actuation is based on its low cost, small size, internal closed-loop position control, low power consumption and easy control signal generation.

To control the servo a pulse train with ON time pulsewidth between 1ms and 2ms is required. The OFF time pulsewidth can be between 10ms and 20ms since it is not critical to the correct operation of the servo. In the case of the ATV throttle control setup shown in Figure 2, a

pulsewidth of 1ms corresponds to idle throttle, 1.5ms half-throttle and 2ms full throttle. Speed feedback is obtained via a tach generator mounted in the gearbox. The tachometer is a Servo-Tek SB-763-2A, designed for use in applications requiring an output signal between 1 and 10volts/1000RPM. The output of the tachometer is connected to a DM5416 Real-Time Devices analog/digital I/O board on the PC/104 stack.

3.1 Polaris Variable Transmission (PVT)

The power train setup of the ATV employs an automatic transmission system called the Polaris Variable Transmission (PVT). The PVT effectively transmits the torque generated by the engine to the four wheels. The PVT changes engine-load requirements by either up-shifting or down-shifting. The PVT system consists of three key components: 1) drive clutch, 2) drive belt and 3) driven clutch.

The drive clutch and driven clutch control the ATV's clutch engagement, from initial vehicle movement to clutch up-shifting and down-shifting. The drive clutch is essentially an RPM sensing unit which effectively transfers the maximum amount of horsepower from the engine to the ground.

The driven clutch is primarily a torque-sensing unit. The drive clutch and driven clutch combine to move the drive belt up and down their sheaves in order to maintain optimum engine RPM in the face of varying engine loads (Manual 1995).

A drawback of the PVT is slippage as a result of overheating or ingestion of oil, water etc into the PVT system. Moving the vehicle at very low speeds (5MPH and lower) induces slippage, since the PVT is optimized for speeds above 15MPH.

4 Engine Mathematical Model

The rotational dynamics of the engine can be modeled as (Alexander G. Loukianov 1997):

$$J_e \dot{N} = T_I - T_f - T_L \quad (1)$$

where N is engine speed (RPM), J_e is engine moment of inertia, T_I is indicated torque, T_f is the friction torque, T_L is external load torque (assume to be constant or slowly varying in comparison with the other variables).

Friction torque can be expressed in terms of engine speed as follows

$$T_f = d_1 N + d_2 \quad (2)$$

where d_1 and d_2 are constants.

Engine indicated torque is applied at the crankshaft due to cylinder pressure during the combustion stroke action through the piston connection rod assembly and the crankshaft angular speed. Indicated torque is defined as

$$T_I = c_t \frac{\dot{m}_{ao}}{N}, \text{ where } c_t = \frac{\eta_e Q_c}{A/F} \quad (3)$$

where η_e is engine efficiency, Q_c is combustion heat, A/F is air to fuel ratio.

The air mass flow rate \dot{m}_{ao} from the intake manifold to the cylinders is defined as,

$$\dot{m}_{ao} = c_e \eta_{vol} m_a N, \text{ where } c_e = \frac{v_e}{4\pi v_m} \quad (4)$$

where v_m is intake manifold, v_e is engine displacement and η_{vol} is volume efficiency of the engine. The air mass flow rate into the intake manifold \dot{m}_{ai} can be approximated by a function in terms of manifold pressure P_m and throttle plate angle α , and is defined below;

$$\dot{m}_{ai} = G(P_m) V(\alpha) \quad (5)$$

where $V(\alpha)$ is modeled as second order polynomial (George Vachtsevanos 1992), defined below

$$V(\alpha) = D_2 \alpha^2 + D_1 \alpha + D_0 \quad (6)$$

where D_2 , D_1 and D_0 are constants. The function $G(P_m)$ is an airflow function of the manifold pressure. Whenever the manifold pressure is less than $1/2$ atmosphere pressure, the pressure ratio across the throttle plate valve is less than $1/2$. Under these conditions airflow is sonic and the function $G(P_m) = 1$ (George Vachtsevanos 1992). For most engines, idle manifold pressure will be such that idle airflow is sonic. Conservation of mass within the manifold requires that

$$\dot{m}_a = \dot{m}_{ai} - \dot{m}_{ao} \quad (7)$$

Substituting equations (3), (2), and (4) into equation (1) and after some simple manipulations gives

$$\dot{N} = \frac{-d_1}{J_e} N + \frac{c_t c_e \eta_{vol}}{J_e} m_a - \left(\frac{d_2}{J_e} - T_L \right) \quad (8)$$

The time derivative of \dot{N} is

$$\ddot{N} = \frac{-d_1}{J_e} \dot{N} + \frac{c_t c_e \eta_{vol}}{J_e} \dot{m}_a \quad (9)$$

Substituting for \dot{m}_a in equation (9) and after some simple manipulation gives

$$\begin{bmatrix} \dot{N} \\ \ddot{N} \end{bmatrix} = \begin{bmatrix} \frac{-d_1}{J_e} & 0 \\ \frac{-c_t c_e \eta_{vol}^2 m_a}{J_e} & \frac{-d_1}{J_e} \end{bmatrix} \begin{bmatrix} N \\ \dot{N} \end{bmatrix} + \begin{bmatrix} 0 \\ \frac{c_t c_e \eta_{vol} D_1}{J_e} \end{bmatrix} \alpha + \hat{E} \quad (10)$$

where higher order, cross coupling terms and load torque have been lumped into \hat{E} .

5 Design Objectives

The speed control system should be designed to provide smooth throttle movement, zero steady-state speed error, constant vehicle speed over varying road slopes, and robustness to system variations and operating conditions for a 2MPH to 30 MPH speed range. Additionally, the number of control calibrations for different vehicle applications should be minimal.

6 Speed Control Design and Results

The two main challenges in designing an effective speed controller for the ATV are 1) the lack of a complete mathematical model for the engine, and 2) the highly nonlinear nature of the engine dynamics, especially for the targeted low speed range of 3-30MPH. Both of these factors make the use of classical control strategies such as PID control ineffective.

One of the main reasons for these challenges is the ATV's carburetor. Carburetors are general calibrated for a fixed range of altitudes and ambient temperatures. Since maximum engine efficiency and horsepower are directly related to proper carburetor setting, any significant changes in altitude and ambient temperatures require recalibration of the carburetor, a tedious task. In contrast, modern engine control systems employ microprocessor-based systems to control fuel injection and ignition point. Engine control strategies depend strongly on the current operating point, and there are no complete mathematical models of the engine parameters. As a result most engine controllers use look-up tables to represent the control strategy. These tables are generated from extensive field experiments and engineering expertise. Therefore, it is very difficult to employ conventional control techniques that require a precise mathematical model to synthesize a speed control algorithm.

Our initial work involved conducting open-loop experiments on the throttle setup shown in Figure 2. Experiments conducted on level terrain showed that humans could not easily drive the ATV at speeds below 10MPH, shed light on the nonlinear nature of the problem. Valve openings below half-throttle did not generate constant speeds. Also, the throttle valve-opening threshold for initiating vehicle movement varied from one trial to the next, indicating a shifting operating point.

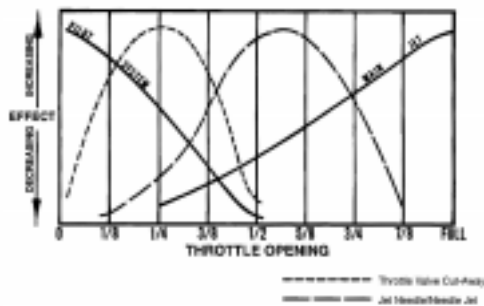

Figure 3 Throttle Opening Chart

An incremental approach with respect to complexity was taken in closing the control loop. A simple initial strategy was a proportional or on-off controller, but due to non-linearities, including delay, involved with the carburetor control action and the PVT, hunting and overshoot of the commanded speed occurred. An obvious modification to the proportional control law was the addition of an integral component to form a PI controller. Although the PI controller has been shown to be a good solution to fixed operating-point plants, it fails when applied to moving operating points. (The measured speed signal is very noisy, so it was not feasible to implement a derivative component for a PID controller). The operating point of the ATV's engine moves with respect to changing load conditions, slippage in the PVT and the carburetor characteristics as shown in Figure 3. Nevertheless, a PI controller can be used for higher speeds where the carburetor operation is fairly linear, i.e., throttle openings above one-half and speeds above 15MPH, covering the upper portion of our target speed range. This result indicates that a possible approach is to use more than one control strategy via lookup tables, depending on the speed range.

Another approach to the control problem is to apply adaptive control techniques. However, a complete mathematical model of the engine parameters is not available, and developing this model requires information about the engine from the manufacturer which they were unwilling to provide. An alternative control approach is fuzzy logic control, since the extensive quantitatively and qualitatively results can be employed effectively in fuzzy systems. From the quantitative data collected, a very primitive engine model was developed using equation (10).

6.1 Fuzzy Logic Speed Control

Fuzzy logic control (FLC) has been demonstrated to solve some practical problems that have been beyond the reach of conventional control techniques. Fuzzy logic control is a knowledge-based control that uses fuzzy set theory, fuzzy reasoning and fuzzy logic for knowledge representation and inference (Trebilcock 1996). The apparent success of FLC can be attributed to its ability to incorporate expert information and generate control surfaces whose shape can be individually manipulated for different regions of the state space with virtually no effects on neighboring regions.

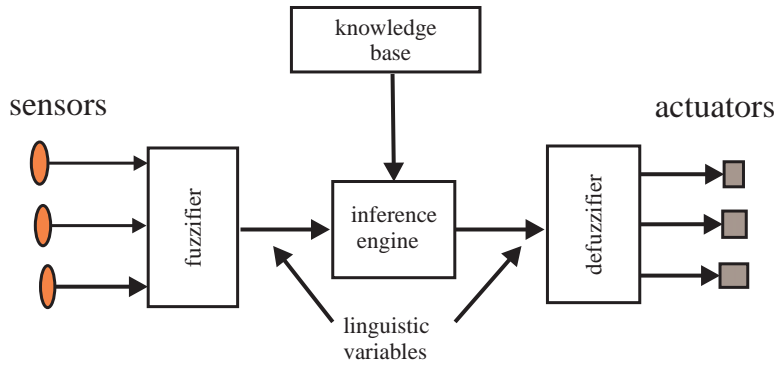

Figure 4 A block diagram of fuzzy logic controller with fuzzifier and defuzzifier

In this paper a fuzzy system consisting of a fuzzifier, a knowledge base (rule base), a fuzzy inference engine and defuzzifier will be considered (see Figure 4). The knowledge base of the fuzzy system is a collection of fuzzy IF-THEN rules.

Fuzzy logic control is ideal for the ATV control problem, since there is no complete mathematical model of the engine. However, human experience and experimental results, can be used in the control system, design. The design goal for the speed control is to minimize the magnitude of the speed error, defined as

$$\text{Speed Error} = \text{Desired Speed} - \text{Actual Speed} \quad (11)$$

Human operators control the speed of the ATV via the throttle lever, which opens and closes the throttle valve to increase or reduce the speed of the ATV. From this experience, fuzzy rules were formulated using speed error and change in control input to the throttle actuator (CTO). CTO is defined using the two past values of the control input, which can be expressed as follows

$$\text{CTO} = \text{Control Input}_{(k-1)T} - \text{Control Input}_{(k-2)T} \quad (12)$$

Discrete time $t = kT$, where $k = 0,1,2, \dots, n$, and T = the sampling and control update period .

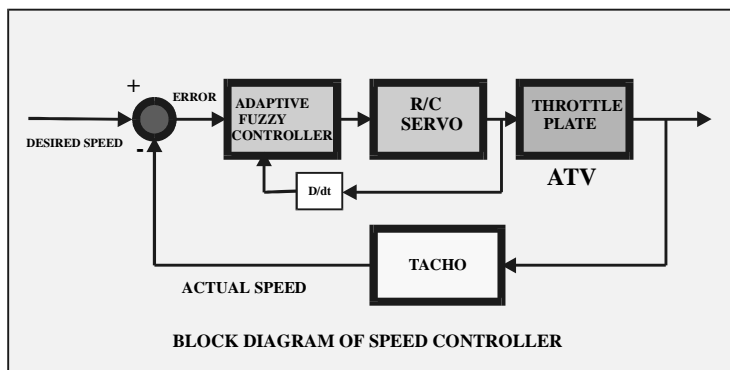

Figure 5 Block diagram of the fuzzy logic control scheme

A block diagram of the control structure is shown in Figure 5. Five triangular membership functions were defined for speed error (see Figure 6) namely, Negative Large (NL), Negative Small (NS), Zero, Positive Small (PS), and Positive Large (PL). Similarly three triangular membership functions were defined for CTO (see Figure 7) and there are as follows, Negative Small (NS), Zero, and Positive Small (PS). Also five triangular membership functions were defined for throttle opening (see Figure 8) and there are Zero, Small, Medium, Large and Very Large. The ranges of these variables were determined by experimentation and the physical constraints of the sensors employed, e.g., R/C servomotor input command range 1ms to 2ms. The complete fuzzy rules are shown in Table 1. The first rule is outlined below,

Rule 1:

If Speed Error is PL AND CTO is Zero THEN Throttle Opening is Large.

This rule is fairly intuitive, since if there is a large positive speed error one should open the throttle wider, especially if the throttle opening has changed very little or remained the same from the previous opening, as implied by CTO being Zero. The rest of the rules are derived similarly. The label names used here give an intuitive sense of how the rules apply. Through experimentation and tuning of the membership functions it was determined that the number of rules was sufficient to encompass all realistic combinations of inputs and outputs.

CTO \ ERROR	NS	ZERO	PS
NL	ZERO	ZERO	ZERO
NS	SMALL	SMALL	SMALL
ZERO	ZERO	ZERO	ZERO
PS	SMALL	LARGE	MEDIUM
PL	MEDIUM	VERY LARGE	LARGE

Table 1Fuzzy Rule Table for ATV Speed Controller

The above fuzzy logic controller was implemented using product inference and a center-average defuzzifier.

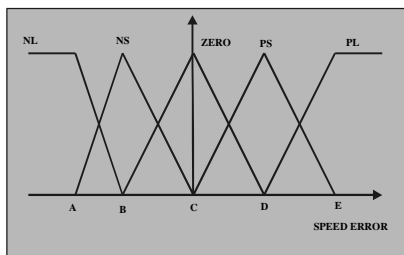

Figure 6 Speed error membership function

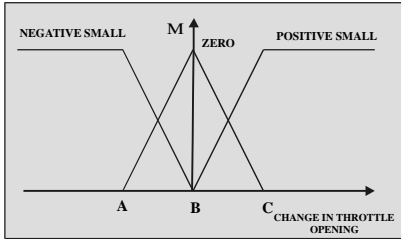

Figure 7 CTO membership function

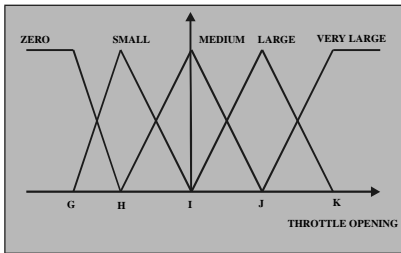

Figure 8 Throttle or control input membership function

Figure 9 depicts the speed response of the ATV using the above fuzzy logic control scheme. There was a fairly large steady state error, but the ATV response was very smooth. Nevertheless, for substantial changes in the terrain (up and down hill) the steady state error was found to increase to an unsatisfactory degree. Several attempts to tune the member functions for fuzzy variables did not significantly reduce the steady state error, suggesting the need for adaptivity. However, in general, most adaptive control schemes require a fairly good parametric model of the plant to be controlled. Since this was not available, adaptive control schemes that do not require a very accurate model of the plant were considered. Since the fuzzy logic control scheme worked fairly well, an adaptive control law based on fuzzy control was considered. The detailed derivation of the adaptation law and control scheme is discussed below.

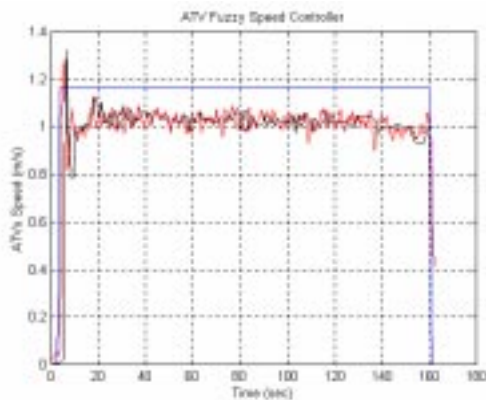

Figure 9 ATV speed response to fuzzy controller, commanded speed 2.3MPH (1.0m/s)

6.2 Adaptive Fuzzy Speed Control

Assume that the rule base consists of multiple-input single-output (MISO) rules of the form

$$R^{(j)} : \text{IF } x_1 \text{ is } A_1^j \text{ and } \dots \text{ and } x_n \text{ is } A_n^j \text{ THEN } y \quad (13)$$

where $\underline{x} = (x_1 \dots x_n) \in N$, y denotes the linguistic variables associated with inputs and outputs of the fuzzy system. A_i^j and C^j are linguistic values of linguistic variables x and y in the universes of discourse N and S respectively, $j = 1, 2 \dots Q_R$ (number of rules). A fuzzy system consisting of a singleton fuzzifier, product inference, center-average defuzzifier and triangular membership functions can be written as (Li-Xin 1994)

$$f(x) = \frac{\sum_{j=1}^{Q_R} \bar{y}^j \left(\prod_{i=1}^n \mu_{A_i^j}(x_i) \right)}{\sum_{j=1}^{Q_R} \left(\prod_{i=1}^n \mu_{A_i^j}(x_i) \right)} \quad (14)$$

where $f : N \subset \mathfrak{R}^n \rightarrow \mathfrak{R}$, $\underline{x} = (x_1 \dots x_n)^T \in N$ and $\mu_{A_i^j}(x_i)$ is a triangular membership function and \bar{y}^j is the point in S where μ_{C^j} is maximum or equal to 1. If the $\mu_{A_i^j}(x_i)$'s and \bar{y}^j 's are free (adjustable) parameters, then equation(14) can be written as

$$f(x) = \underline{\vartheta}^T \underline{\Psi}(x) \quad (15)$$

where $\underline{\vartheta} = (\bar{y}^1, \dots, \bar{y}^{Q_R})$ is a parameter vector and $\underline{\Psi}(x) = (\psi^1(x), \dots, \psi^{Q_R}(x))^T$ is a regression vector with the regressor given by

$$\psi_i(x) = \frac{\prod_{i=1}^n \mu_{A_i^j}(x_i)}{\sum_{j=1}^{Q_R} \left(\prod_{i=1}^n \mu_{A_i^j}(x_i) \right)} \quad (16)$$

Equation(15) is referred to as adaptive fuzzy systems (Li-Xin 1994). There are two main reasons for using adaptive fuzzy systems as building blocks for adaptive fuzzy controllers. Firstly, it has been proved in (Li-Xin 1994) that they are universal function approximators. Secondly, all the parameters in $\underline{\Psi}(x)$ can be fixed at the beginning of adaptive fuzzy systems expansion design procedure, so that the only free design parameters are $\underline{\vartheta}$. In this case $f(x)$ is linear in the parameters. This approach will be adopted in synthesizing the adaptive control law in this paper. The advantage of this approach is that very simple linear parameter estimation methods can be used to analyze and synthesize the performance and robustness of adaptive fuzzy systems. If no linguistic rules are available, the adaptive fuzzy system reduces to a standard nonlinear adaptive controller.

6.2.1 Adaptive Law Synthesis

The engine mathematical model given by equation (10) can be expressed as (A. Trebi-Ollennu 1997)

$$\dot{z} = Az + Bu + E(z) \quad (17)$$

where A is Hurwitz. Therefore there exists a unique positive definite matrix P that satisfies the Lyapunov equation.

$$A^T P + PA = -Q \quad (18)$$

If the control input, u , is expressed as an adaptive fuzzy system then equation(17) becomes,

$$\dot{z} = Az + B \vartheta^T \psi(z) + E(z) \quad (19)$$

Let (Feng 1993), (Trebi-Ollennu 1996),

$$\dot{\hat{z}} = A\hat{z} + B \vartheta^{*T} \psi(\hat{z}) \quad (20)$$

be the ideal engine model with no uncertainty (identification model) with $\varepsilon = z - \hat{z}$, where ϑ^* denotes the optimal ϑ defined as,

$$\vartheta^* \equiv \arg \min_{|\vartheta| \leq M} \left[\sup_{z \in \Omega} |u(z | \vartheta^*) - u(z | \vartheta)| \right] \quad (21)$$

Therefore

$$\dot{\varepsilon} = A\varepsilon + B\phi^T \psi(\varepsilon) + \hat{E} \quad (22)$$

where $\phi = \vartheta - \vartheta^*$. To derive a control law that ensures that $\varepsilon \rightarrow 0$ as $t \rightarrow \infty$ a candidate Lyapunov function is defined as (Li-Xin 1994; Trebi-Ollennu 1996);

$$V = \frac{1}{2} \left(\varepsilon^T P \varepsilon + \frac{\phi^T \phi}{\gamma \|\hat{E}\|} \right) \quad (23)$$

where $\gamma > 0$ is a design parameter. The time derivative of V is

$$\dot{V} = -\varepsilon^T Q \varepsilon + \varepsilon^T P B (\hat{E} + \phi^T \psi(\varepsilon)) + \frac{\phi^T \dot{\phi}}{\gamma \|\hat{E}\|} \quad (24)$$

Rearranging equation(24) yields

$$\dot{V} = -\varepsilon^T Q \varepsilon + \varepsilon^T P B \hat{E} + \phi^T \left(\gamma \|\hat{E}\| \varepsilon^T P B \|\psi(\varepsilon) + \dot{\phi} \right) \quad (25)$$

Now choosing the adaptive law (recalling that $\dot{\phi} = \dot{\vartheta}$)

$$\dot{\vartheta} = -\gamma \|\hat{E}\| \varepsilon^T P B \|\psi(\varepsilon) \quad (26)$$

The equation(25) reduces to

$$\dot{V} = -\varepsilon^T Q \varepsilon + \varepsilon^T P B \hat{E} \quad (27)$$

The equation(27) can be recast using vector norms;

$$\dot{V} = -\lambda_{\min}(Q) \|\varepsilon\|^2 + \|\varepsilon^T P B\| \|\hat{E}\| \quad (28)$$

Let $\|\hat{E}\|$ be selected such that

$$\|\hat{E}\| \geq \frac{\lambda_{\min}(Q) \|\varepsilon\|^2 - \alpha \|\varepsilon\|}{\|\varepsilon P B\|} \quad (29)$$

where $\alpha > 0$, substituting for \hat{E} in equation(29) gives

$$\dot{V} \leq -\alpha \|\varepsilon\| \quad (30)$$

Therefore the control law of equation(26) will ensure that the state ε converges.

To implement the above adaptive fuzzy control law, the fuzzy rule Table 1 was used and the insight gained from the non-adaptive fuzzy logic control was used to select the $\underline{\vartheta}$ values to lie within the interval [1.0,2.0]. The remaining control parameters were set as follows:

$Q = \text{diag}(3,3)$, $\hat{E} = 120$, $\gamma = 0.00025$, $\varepsilon = \text{Desired Speed} - \text{Actual Speed}$, $\Psi(\varepsilon)$ was formulated using the IF part of fuzzy rule Table 1. The adaptive fuzzy controller was also

implemented on the ATV. Figure 10 depicts the ATV speed responses to selected speeds. As can be seen from the figures significant improvement can be observed with respect to steady state error. Considerable improvement was also observed with respect to disturbance rejection (load and terrain).

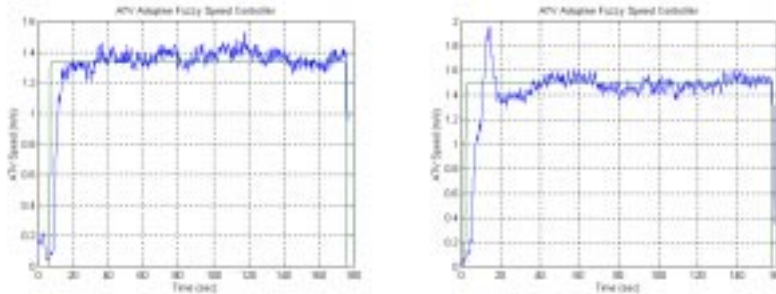

Figure 10 ATV speed responses for adaptive fuzzy throttle controller for 2.97MPH (1.3m/s) and 3.4MPH (1.5m/s) speed commands

Figure 11 depicts the ATV's response to a speed command of 2.3MPH (1.0m/s), a very slow speed. As can be observed from the ATV's response, there is an overshoot, and it takes about 30sec for the speed to settle. The ATV is back-heavy hence, when it is on a slight incline considerable momentum is required to initiate motion. At about 80sec (Figure 11) there is a considerable drop in the ATV's speed to well below the commanded speed of 1.0m/s, which can be attributed to a slippage in the PVT system. The throttle control responds with a small increase, rather than the large response that a PI controller would generate, and regains the commanded velocity without significant overshoot once the slipping stops.

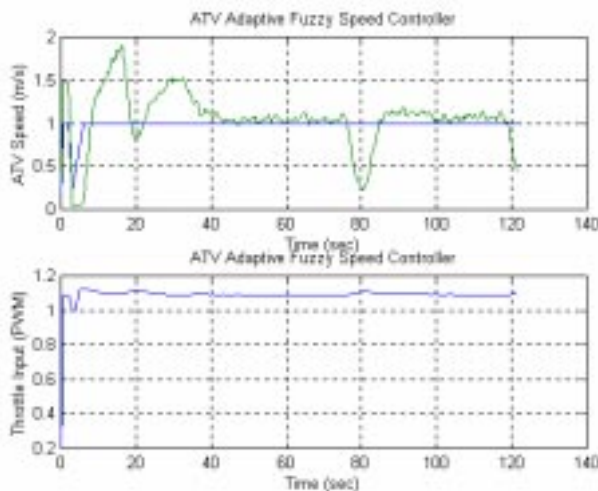

Figure 11 ATV speed response for adaptive fuzzy throttle controller, 1.0m/s speed command

7 Conclusions

We have developed an adaptive fuzzy speed controller for a throttle-regulated internal combustion engine on an ATV. Experimental results presented showed the following desirable properties: smooth throttle movement, robustness with respect to varying terrain and commanded speeds in the range 2MPH to 30MPH. The adaptive fuzzy throttle control algorithm presented here has been implemented on two other ATVs with very little recalibration of the control parameters. The formulation of the fuzzy rules here may be relevant to other practical applications where a complete mathematical model is not available.

8 References

- A. Trebi-Ollennu, B. A. W. (1997). "Robust output tracking for MIMO nonlinear systems: An adaptive fuzzy systems approach." IEE Proceedings, Control Theory and Applications **144**(6): 537-544.
- Alexander G. Loukianov, S. J. D., Wada Hosny and Jan Vittek (1997). A Robust Automotive Controller Design. IEEE International Conference on Control Applications, Hartford, CT, USA.
- Byeong-Jo Lee, Y. -W. K. a. D. -I. C. (1993). "Engine throttle control Using Anticipatory Band in the Sliding Phase Plane." IEEE Transactions on Control Systems Technology **1**(4): 280-284.
- George Vachtsevanos, S. S. F. a. H. K. (1992). A Systematic Design Method for Fuzzy Logic Control with Application to Automotive Idle Speed Control. 31st Conference on Decision and control, Tucson, Arizona.
- Li-Xin, W. (1994). Adaptive Fuzzy Systems and Control Design and Stability Analysis, Prentice Hall.
- M. K. Liubakka, D. S. R., J. R. Winkelman and P. V. Kokotovic (1993). "Adaptive Automotive Speed control." IEEE Transactions on Automatic Control **38**(7): 1011-1020.
- Manual, P. (1995). Service Publications, 1995 -1996 Magnum & 1996 Sportsman 500, Polaris.
- Martin Sommerville, C. H. a. U. O. (1998). "Switching control of a Pneumatic Throttle Actuator." IEEE Control Systems **18**(4).
- Takahashi, H. (1988). Automatic Speed Control Device Using Self-Tuning Fuzzy Logic. IEEE.
- Trebi-Ollennu, A. (1996). Robust nonlinear control designs using adaptive fuzzy systems, Ph.D. Thesis. Department of Aerospace & Guidance Systems, School of Engineering & Applied Science, Royal Military College of Science, Shrivenham, Cranfield University.