

# KDI INITIATIVE: MULTIDISCIPLINARY SCIENTIFIC COLLABORATIONS

December 2003



# KDI INITIATIVE: MULTIDISCIPLINARY SCIENTIFIC COLLABORATIONS

Jonathon Cummings  
Sloan School of Management  
Massachusetts Institute of Technology  
50 Memorial Dr., E52-590  
Cambridge, MA 02142  
cummings@mit.edu

Sara Kiesler  
Human-Computer Interaction Institute  
Carnegie Mellon University  
5000 Forbes Avenue  
Pittsburgh, PA 15213  
kiesler@cs.cmu.edu

December 2003

This work was supported by the National Science Foundation under Award No. IIS-9872996. Any opinions, findings, and conclusions or recommendations expressed in this material are those of the authors and do not necessarily reflect the views of the National Science Foundation.

## Acknowledgements

This evaluation study grew out of a workshop for KDI grantees by the Information and Intelligent Systems Division, Directorate for Computer & Information Science & Engineering, National Science Foundation. Study data on the KDI Initiative depended on the voluntary participation of KDI researchers who attended this workshop and those who answered the follow-up survey. Many KDI researchers also facilitated discussions, contributed ideas for the study, and helped coordinate the workshop. The authors thank all these contributors as well as Michael Lesk, who chaired the workshop, and Suzanne Iacono, whose ideas and support made this study report possible. The authors also thank Allyson Pottmeyer for her diligent and creative work organizing and analyzing the workshop and archival data.

# Table of Contents

- 1 Executive Summary
- 2 About KDI

## Part One: Study of the KDI Initiative

- 5 Introduction
- 7 Workshop
- 8 Post-Workshop Survey

## Part Two: Results of the Study

- 10 Disciplines Represented
- 13 Outcomes
- 14 · Ideas
- 16 · Tools
- 18 · Career Development
- 20 · Project Outreach
- 23 Dispersion in Projects
- 25 Outcomes in Dispersed Projects
- 27 The Important Role of Coordination
- 30 Coordination and Outcomes
- 33 A Successful Dispersed Project

## Part Three: Recommendations

- 36 Program Management for Multidisciplinary Collaboration

## Appendix

- 40 KDI Projects

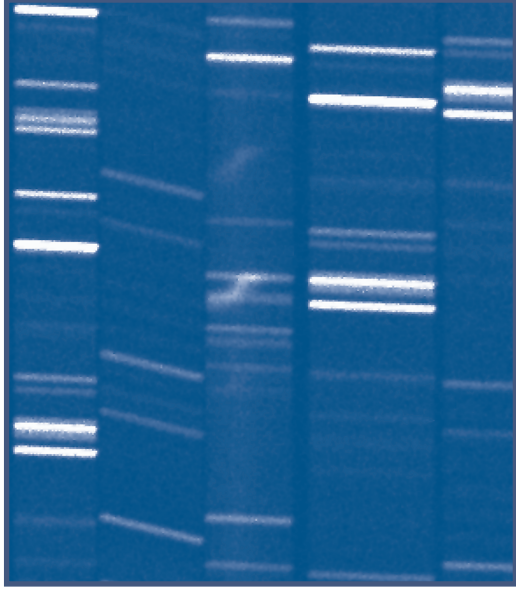

# Executive Summary

The research enterprise increasingly involves multidisciplinary collaborations, sometimes over geographic distance. Technological advances have made these collaborations possible, and the history of past innovations suggests these collaborations are highly desirable. Yet ambitious collaborative projects can carry high coordination costs.

The authors conducted an evaluation study of 62 scientific collaborations supported by the 1998-1999 KDI program of the U. S. National Science Foundation. These projects were multidisciplinary and often dispersed geographically. Many were highly successful, as judged by their generation of new knowledge and areas of work, development of tools and infrastructure for science, training of scientists and engineers, and project outreach to schools and the public. A significant barrier to this success was geographic dispersion of projects, defined as the number of different universities collaborating in a project. Geographically dispersed projects reported fewer positive outcomes than collocated projects. Dispersion tended to increase with multidisciplinary, but statistical analysis suggests that geographic dispersion of projects, rather than their multiple disciplines, was problematic for projects.

The authors identified too little coordination as the reason why geographically dispersed projects were less successful, on average, than collocated projects. Geographically dispersed projects were

significantly less well coordinated than collocated projects were, leading to reduced communication and integration of the researchers across the entire project. Some projects reduced the negative impact of being dispersed by employing mechanisms that brought researchers together physically. For example, projects in which the investigators arranged occasional workshops or conferences, during which researchers worked together, were more successful. However, most dispersed projects did not make use of these effortful coordination mechanisms, or they did so only in the first year of the project.

The study findings suggest that multidisciplinary collaborations need to be organized and managed for good coordination throughout the whole project, and that successful dispersed projects must spend additional time and resources on coordination. The authors recommend that program officers managing multidisciplinary programs support and facilitate the extra coordination needed in multidisciplinary projects that are geographically dispersed.

## About KDI

The official name of the U.S. National Science Foundation (NSF) program known as "KDI" is Knowledge and Distributed Intelligence. NSF developed KDI as a foundation-wide interdisciplinary research initiative. The purpose of this program was "to span the scientific and engineering communities...to generate, model, and represent more complex and cross-disciplinary scientific data from new sources and at enormously varying scales." The program was very competitive. It supported just 40 awards out of 697 proposals in 1998 and 31 awards out of 554 preproposals (and 163 full proposals) in 1999. These projects were supported at \$1.5M each, on average, and were to run 3 or 4 years.

Why KDI? At the turn of the millennium, science policy makers recognized that the explosive growth in computer power and connectivity was reshaping relationships among people and organizations, and transforming the processes of discovery, learning, and communication. They recognized an unprecedented opportunity to provide fast access to enormous amounts of knowledge and information, to study much more complex systems than was hitherto possible, and to advance our understanding of living and engineered systems. To achieve these goals, though, the NSF would need to foster more multidisciplinary research, especially projects including the computer sciences and the other sciences and engineering. The KDI goal was to support research that would model and make use of

complex and cross-disciplinary scientific data. The research would analyze living and engineered systems in new ways. It would also explore the cognitive, ethical, educational, legal, and social implications of new types of learning, knowledge, and interactivity. It would foster scientists' sharing knowledge and working together interactively. Richard Zare, chairman of the National Science Board and professor of chemistry at Stanford University, wrote in *Science*, "This knowledge and distributed intelligence (KDI) initiative would promote collaborations that seem long overdue, such as linking the science of learning and cognition with the development of technologies for teaching and learning" (1997, vol. 275, 21 Feb, p. 1047).



**PART ONE:  
STUDY OF THE KDI INITIATIVE**



A sagittal magnetic resonance image (MRI) of the brain. NSF-supported fundamental research led to the development of MRI technology. Image courtesy FONAR Corporation.

# Introduction

The principle question we address in this report is whether, and how, scientific collaborative projects involving multidisciplinary and geographic dispersion achieve successful outcomes.

Scientists have collaborated with one another for centuries. Some of the last century's most remarkable innovations derived from work across disciplines and laboratories. James Watson and Francis Crick, physicists-turned-biologists who discovered DNA structure in 1953, shared the same office in Cambridge, and talked for hours and days on end. Nonetheless, their achievement was not made in isolation; for instance, it also depended on their knowledge of Rosalind Franklin's advances in crystallography, coming out of her lab at Kings College in London

From such examples, scientists and policy makers have begun to encourage and support multidisciplinary collaboration in applied and basic science. Important fields such as oceanography and cognitive science have developed out of multidisciplinary collaboration.<sup>1</sup>

Multidisciplinary projects can foster invention, the development of new areas of inquiry, and the development of careers in the frontiers of science and engineering.

There is a tension inherent in multidisciplinary collaboration. Because the formal organization of science and engineering work mainly mirrors fields, multidisciplinary collaboration often requires crossing organizational boundaries. The geologist who collaborates with a computer scientist typically works in a different department or even in a different university. In the past, such dispersed collaborations were very difficult; physical distance and conflicting institutional commitments not only reduced the likelihood of these collaborations, but also had a negative impact on their success.<sup>2</sup> The current explosion in

dispersed collaboration has occurred, in part, because computer-based tools and technologies allow scientists to more easily share information, data, reports, equipment, instruments, and other resources.<sup>3</sup> Thus, as the Internet and other forms of computing enhanced the potential for "distributed intelligence," we have raised our expectations of the ability to collaborate across fields and organizations.

Yet recent research suggests that technology has not yet conquered distance.<sup>4</sup> A significant challenge for dispersed scientific collaborations is coordinating work so that scientists and students participating in projects can leverage one another's ideas and expertise without frequent face-to-face interaction.

Although projects accomplish some coordination by establishing clear areas of responsibility and division of labor, successful research is dynamic and integrative. Members of the collaboration must talk out common problems, discuss shared resources, and monitor and review the work together to make joint progress. Multidisciplinary should increase the likelihood of innovation due to the juxtaposition of ideas, tools, and people from different domains. But if scientists are separated and work alone, they do not benefit from this mix of intellectual resources.

How successfully have today's scientists overcome the challenges of multidisciplinary and geographic dispersion? This study provides some insights into the kinds of coordination and resources for coordination that ambitious science and engineering programs must provide if such projects are to be successful.

1998



697 proposals

40 NSF Awards

1999



554 pre-proposals  
163 proposals

31 NSF Awards  

---

71 KDI Projects

2002



Spring

Workshop

*52 KDI Projects Represented*

- experiences
- outcomes
- suggestions

Fall

Online questionnaire

*62 KDI Projects Represented*

- coordination mechanisms
- project outcomes

2003



Analysis



## Workshop

In the Fall of 2001, NSF organized a workshop of research grantees to assess the KDI research projects. The principal investigator (PI) and one co-PI from each of the 71 KDI projects were invited. Researchers from 52 research projects attended the workshop, held in late April, 2002. At this workshop, the authors used a documented discussion procedure to learn how research projects were organized and managed, the kinds of outcomes they generated, and the ways in which the research experience of these investigators could inform future programs and program evaluation. The participants contributed a large body of material, including copies of reports and papers, and links to project websites. During three mornings of small group discussion, note takers at each table created lists of experiences, outcomes, and suggestions.

During the workshop, it became clear that beneficial KDI project outcomes could not be captured by any single measure, such as publications. Some KDI projects did publish considerable literature but others opened up an entirely new field of scientific endeavor that the researchers continued to pursue in subsequent projects. Other KDI projects mainly produced new research tools, such as software that could be used by other researchers or even in other fields. Some projects successfully trained graduate students who went on to good research jobs, or these projects gave undergraduates the experience they needed to win places in excellent graduate programs. Others worked with community groups to bring science to the public, for example, through museum exhibits, elementary school classroom materials, or websites designed for the public. A significant lesson from the variety of successful outcomes described in the KDI grantees workshop was that studying research project outcomes would require a broad perspective on evaluation. Thus, the authors created a master list of the

diverse project outcomes reported at the workshop; subsequently they included these outcomes in a statistical analysis of factors leading to project success.

Almost all of the KDI researchers at the workshop reported facing serious obstacles to collaboration. These obstacles ranged from the different teaching schedules of principal investigators, to different visions within the project of where the project should go. For example, one PI, whose university ran on the semester system, had difficulty finding times to meet with his co-PIs, whose universities ran on the quarter system. Another talked about how he had to negotiate budgets, contract language, intellectual property, indirect costs, and human subjects procedures across universities.

To overcome collaboration obstacles, researchers employed many traditional approaches to research coordination, such as holding weekly research lab meetings. When these approaches were not possible, as when the project was geographically dispersed, researchers devised other mechanisms to aid communication and keep the project on track. For instance, some PIs arranged for graduate student exchanges to promote cross training of students in the project. Because coordination arose as a highly significant issue at the workshop, the authors examined how coordination was related to the success of KDI projects, and whether certain coordination mechanisms functioned better than others.

## Post-Workshop Survey

From the workshop results, the authors created an online questionnaire to systematically assess project outcomes and the coordination mechanisms that workshop participants described in connection with their own projects. Items on the survey represented each of these project outcomes and coordination mechanisms.

In the fall of 2002, notice of the survey went to all KDI PIs and co-PIs and a random sample of students and staff in each project. The survey asked respondents if their project had experienced each outcome or used any of the listed coordination mechanisms. The items measuring project outcomes were presented within categories corresponding to NSF's goals for research programs: generation of new ideas and knowledge, generation of tools and infrastructure for research, training and career development of scientists and engineers, and project outreach to improve public understanding and use of science and engineering. Respondents checked whether their project had achieved outcomes within each of these categories, and if so, they were asked to document these outcomes.

Survey items measuring coordination included traditional mechanisms such as direct supervision of work and routine lab meetings, as well as use of special events or procedures, such as holding workshops to get people together in the same place, traveling to work together, sending graduate students to other sites, and using email and

telephone. If respondents checked an item, they were asked to document how they used this mechanism in their project.

The authors subsequently analyzed data from this survey statistically, using factor analysis to confirm response categories, and regression to examine how project factors predicted successful outcomes and coordination in the KDI projects.

PART TWO:  
RESULTS OF THE STUDY

# Disciplines Represented

Each project in the sample of 62 projects had one PI and up to five co-PIs; the average number of co-PIs was three. The PIs on the projects represented over 40 disciplines, including computer science, electrical engineering, psychology, physics, mathematics, and biology.





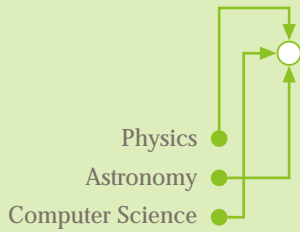

## Pooling Data in Astronomy and Particle Physics

High-speed computer networks and breakthroughs in telescopes now allow astronomers and particle physicists to collect vast amounts of data in very short periods of time. These advances have created a problem: A scientist cannot look through or comprehend all these data. That fact prompted Dr. Alex Szalay and his collaborators to propose the KDI-funded project, Accessing Large Distributed Archives in Astronomy and Particle Physics

# Illustrative Multidisciplinary Projects

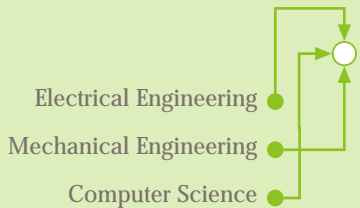

## Engineers Study Design Collaboration

When engineers build something, they typically come up with lots of ideas and the final design uses only a few. What happens to the discarded ideas? What if you could capture those ideas so that other designers could access that data and expertise? A designer could then search design repositories, much as we search the Internet today, and pull out ideas to use for a new problem. This problem challenged a team led by the University of Michigan in a KDI project, Creating a Corpus of Learning-Situated Design Guidelines & Software Components.

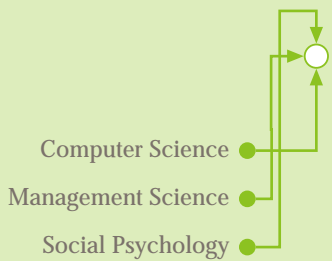

## The Importance of Shared Visual Environments for Collaborative Tasks

How does a virtual team work together across distance? For instance, is remote surgery really feasible? Problems arise when separated members of a team must work on physical objects and learn manual and spatial skills from one another. This collaboration at Carnegie Mellon University has developed widely-imitated scientific behavioral experiments to identify the best way for dispersed team members to share a visual space and be able to work together on important elements of the tasks.

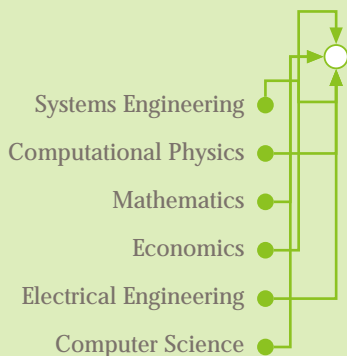

## Manufacturing Supply Chains and Networks

Innovative research in multiple scale based complex system decomposition and algorithm development is breaking ground across a variety of scientific fields. A multidisciplinary team of scientists from among the nation's top universities and research organizations is decentralizing decisions in complex systems that bog down manufacturing, tie up Internet traffic, and stifle growth and development in others areas of the global economy. This project has provided major industries with a scientifically valid set of methods for making better planning and operational decisions faster and more efficiently than previously possible.

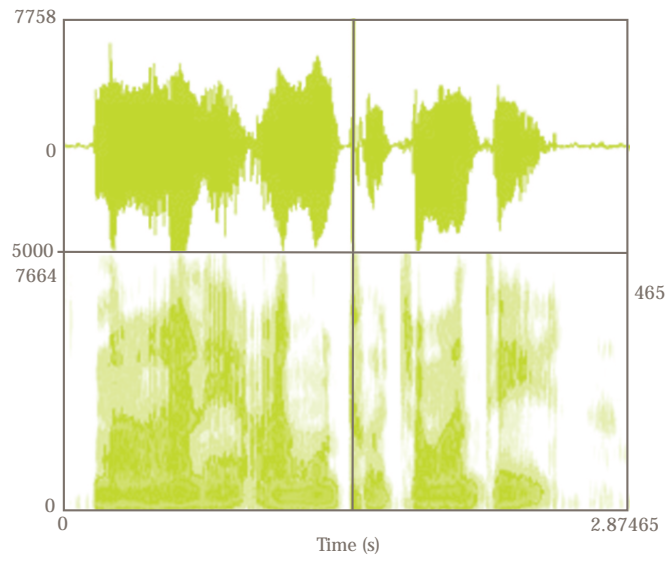

## Project Outcomes

The KDI program goals were to foster new ideas, innovative computer-based tools, and career development of scientists and engineers who could collaborate in new, multidisciplinary areas. Each project also had its own specific goals. For example, one project had the goal of modeling the earth in three dimensions to better predict oil reserves. Hence, as became clear in the workshop, no single metric would be sufficient to evaluate KDI, and any single metric would be misleading.

To analyze the various outcomes the projects reported, the authors conducted a factor analysis of all outcomes. Four major factors resulted. One factor, “New Ideas,” included such outcomes as publishing peer-reviewed articles and books and jumpstarting a new scientific field. A second factor, “New Tools,” included such outcomes as the development of databases that could be shared across disciplines, and new software for scientific analysis. A third factor included career development and training outcomes. The fourth factor represented project outreach efforts that contributed to the public understanding and use of science. These factors map well onto the National Science Foundation goals for research programs: generation of new ideas and knowledge, generation of tools and infrastructure for research, training and career development of scientists and engineers, and project outreach to improve public understanding and use of science and engineering. To illustrate these diverse outcomes, this report lists some of the outcomes of KDI projects and describes in further detail a few of the KDI projects.

## Some Outcomes of KDI Projects: New Ideas



---

Algorithm for large-scale predictive species distribution

---

3D optical and magnetometer signals for speech

---

Combined game logic and algorithms

---

Blood flow simulation around prosthetic heart valves

---

Multi-electrode recording MEG and fMRI

---

New approach to coordinated flight

---



Structure-based vehicle detection/tracking

---

Use of eye movements to study language production

---

Digital language archives

---

Brain machine interfaces

---

Performance analysis of comparative gene finders

---

Ecological informatics

---

Digital technologies for archaeology

---

Application of conservation laws to interface motion

---

# The Coordinated Flight of Birds and Unmanned Planes

What makes birds fly in flocks and fish swim in schools? And once you know the answer, can you use it to make unmanned airplanes fly in groups? These issues fall into the area of control systems, the focus of Dr. Ali Jadbabaie's research.

Dr. Jadbabaie is an assistant professor in the Department of Electrical and Systems Engineering at the University of Pennsylvania and a member of the General Robotics, Automation, Sensing and Perception (GRASP) Lab at the university.

Dr. Jadbabaie got his Ph.D. at California Institute of Technology in control and dynamical systems. He then worked as a postdoc on the KDI-funded project Coordinated Motion of Natural and Man-Made Groups. Under the direction of the project's principal investigator, Dr. Stephen Morse from Yale, the multidisciplinary team of control theorists, marine biologists, and evolutionary biologists researched how natural groupings—swarms of bees and herds of deer, for example—coordinate themselves and move flawlessly, usually without an obvious leader or form of centralized control. "The biologists were studying different species of animals," says Dr. Jadbabaie, "and they were trying to understand what the evolutionary advantages were for the animals to move in a group or flock. We (the control theorists) were trying to see, from a mathematical point of view, how it's possible to have a stable global behavior in the absence of global information exchange."

According to Dr. Jadbabaie, "In the course of doing the literature survey, we realized that this problem is something that has been studied one way or another across many different disciplines. People in control theory, in computer graphics, in statistical physics had all been looking at the general problem of how it is that you can have a group of man-made or natural agents interact with each other locally using simple, local information and how a complicated global behavior emerges

from this interaction."

The group was interested in studying this problem rigorously, and with the help of Dr. Jadbabaie's research, they were able to explain the behavior they had observed. Models in physics as well as in computer graphics had been used to explain how a group of moving objects with only local interaction can reach consensus about what direction they want to go in. The team provided a mathematical proof and justification for why this happened and generalized it to several situations.

Dr. Jadbabaie's work on the KDI project has led him to continue studying group coordination, but now of man-made groups. He explains, "I'm interested in how we can develop a group of unmanned autonomous vehicles, air vehicles or ground vehicles, that coordinate with each other without centralized supervision." The military is very interested in this research because of the trend toward unmanned military operations. Researchers hope to have a group of airplanes interact with one another, with a human providing only a high-level mission objective, a map, and periodic updates. According to Dr. Jadbabaie, "On the surface, the problem of planes and birds is very different, but if you study the mathematics behind it, you see that it is related."

Currently, the military uses unmanned planes for reconnaissance missions. But the direction of Dr. Jadbabaie's research is, first, to enable planes to work in a group and second, to use them for more aggressive tasks. "The goal is that eventually—over the next 15–20 years—you'd replace a squadron of jets with a squadron of unmanned air vehicles," says Dr. Jadbabaie.

## Some Outcomes of KDI Projects: New Tools



---

System to support manual manipulation of virtual objects

---

Web interface for analyzing and mapping species

---

Speech data collection and analysis program

---

Program to calculate fluid-structure interaction 

---

Hardware technology for tracking facial expressions

---

Web-based tutoring system for cognitive science

---

Dynamic lead time production scheduling software

---

Software environment for polycrystal sample generation

---

Code for analysis of multielectrode data

---

Language acquisition by autonomous robot program

---

Software for relativistic astrophysics simulation

---

Database of special functions of applied mathematics

---

Open source resource for others doing surgical simulation

---

# Direct Numerical Simulation and Modeling of Solid-Liquid Flows

Recent advances in computers and software have made possible exciting new research in science and engineering.

These powerful technological tools are key to the work of Dr. D. D. Joseph and his team in their project "Direct Numerical Simulation and Modeling of Solid Liquid Flows," which focused on computing the motion of solids in liquids using what is called direct numerical simulation.

Solids in liquids, such as particles in an oil pipeline or sediment in a river, interact with one another. Dr. Joseph and his team used high-speed computers and innovative software to create three-dimensional direct numerical simulations of the interactions of thousands of particles, so that they could understand and predict their collective behavior.

In the past, these predictions were an inexact science. According to Dr. Joseph, the project's Principal Investigator and Regents Professor at the Department of Aerospace Engineering and Mechanics at the University of Minnesota, "Prior to the introduction of this method, people would compute these motions using models, which were left to researchers' imaginations, and by and large always led to one defect or another."

But thanks to this National Science Foundation-funded project, researchers can now study the interaction of the solids in new ways. "There are certain physical effects, like the rotation of a particle, that occur in experiments," explained Dr. Joseph. "But in direct numerical simulation, we can suppress those things or include those things. We can examine separate physical effects one at a time, so we can do things in numerical experiments that we can't do in real experiments."

These computations create very large amounts of data, which Dr. Joseph and his team use in numerous ways. "We can process the data to find formulas which give rise to an expression for the lift force, or an expression for the drag, or an expression for the expansion of [chemical reactors called] fluidized beds as you increase the velocity, or an expression for the lift-off of the sediment." This has important applications in the chemical process industry and the field of oil exploration and recovery.

Direct numerical simulations also save time and effort. "The same methods that we use, we can use in real experiments and we can use in numerical experiments," says Dr. Joseph. "So it opens up a huge opportunity in the future for shortcutting actual experimentation with numerical experimentation." Models can be compared to direct numerical simulations. Direct numerical simulations can also help suggest new models, and in some cases, they can replace models entirely.

What makes this aspect of the work particularly exciting, says Dr. Joseph, is that in addition to the two branches of scientific inquiry that already existed—mathematical analysis and experiments—there is now a third: numerical experiments. The original two will "continue to be an aspect of scientific culture that will produce and produce," says Dr. Joseph. "But we know all about what they can do. They're not new items. The boundaries of what can be produced by numerical experiments have not yet been established."

For this project, Dr. Joseph assembled a team of experts in fluid mechanics, computational fluid dynamics, and computer science from around the country. They include Yousef Saad (the project's co-PI), Professor in the Department of Computer Science and Engineering at the University of Minnesota; Roland Glowinski, the Cullen Professor of Mathematics and Mechanical Engineering at the University of Houston; Gene Golub, the Fletcher Jones Professor of Computer Science at Stanford; and Ahmed Sameh, the Samuel Conte Professor of Computer Science at Purdue. Also involved were a number of postdocs and graduate students.

Dr. Joseph says, "We've been very successful in this. It could be said that we are the leading group in this method of direct numerical simulation of solid-liquid flow."

## Some Outcomes of KDI Projects: Career Development



---

Graduate student finished thesis on learning in a flight training setting

---

Undergraduate thesis was published in top journal

---

KDI research was incorporated in doctoral dissertation

---

Student moved to aviation research unit of major company

---

Two Master's theses were completed

---

Postdoc got assistant professor job

---

Ph.D. thesis on topic was completed

---



Ph.D. student defended thesis on modeling traffic dynamics

---

Student got an academic job teaching linguistics at Northwestern

---

Graduate assistant received a prestigious postdoc at Yale

---

Student got a job at Rand Corporation

---

Staff member got an academic appointment

---

First ever Stanford B.S. honors thesis in MS&E

---



# A Computer Scientist's Education

Amy Greenwald is a computer scientist whose work focuses on artificial intelligence, specifically multi-agent interactions and game theory.

She did her undergraduate work in a dual degree program at the University of Pennsylvania, where she studied both computer science and economics, which, in essence, remain her focus. But, says Dr. Greenwald, "I can't say that early on I knew that was exactly what I wanted to do. Computers and economics made for a great program and a great opportunity, so I took advantage of it, but my career zigzagged around a little bit before I came back to it."

That zigzagging took her first to Oxford, where she had won a scholarship. With the focus on computer theory at Oxford, Dr. Greenwald says that she "veered off from economics and computer science into logic and computer science." She got a master's degree at Oxford and returned to the United States to start her Ph.D. at Cornell. Because Cornell has a very strong group in logic and computer science, she stayed with that focus. After a few years, she realized that combination wasn't what she wanted, and in 1995 she left Cornell and went to New York City.

While interviewing for jobs and considering how best to continue her doctoral studies, Dr. Greenwald sat in on a class at City University of New York because one of her advisors at Cornell had recommended the professor, Dr. Rohit Parikh. "Of all the things I did in that period," says Dr. Greenwald, "I liked the courses at City University the best." Although she decided to go to New York University (NYU) for her Ph.D., Dr. Parikh served on her thesis committee, and the collaboration between the two prospered.

The NYU computer science building happened to be right across the street from the business school. "I was just starting out at NYU," says Dr. Greenwald, "and I was looking for a new thesis topic. I knew I was going to do something with economics and computer science. One day I happened to sit in on a game theory class at the business school, and that completely changed my career interest."

Since then, Dr. Greenwald has been doing research on computer science and game theory. She worked as a postdoc on the KDI project Automated Learning in Network Traffic Control, along with her advisor from NYU, Dr. Bhubaneswar Mishra (the project's principal investigator) and Dr. Parikh (co-principal investigator), among others.

For the project, Dr. Greenwald did work on resource allocation. The team started with a problem called the "Santa Fe bar problem," which assumes that there is a bar in Santa Fe that has live music on Thursday nights. The bar seats 60 people, but every Thursday night 100 people want to go. The problem is to figure out, on any given Thursday night, whether to go-and risk finding out there's not enough room-or stay home, only to learn that there were plenty of seats and then wish you had gone. The team modeled the program game theoretically, and eventually, using low-rationality algorithms, they were able find a way for a different set of 60 people to go to the bar each time. Dr. Greenwald says, "We were viewing this just like sending packets along a network link. It's a similar problem. It's as if you wanted, for example, to send 100 packets and only had capacity for 60."

Today an assistant professor in computer science at Brown University, Dr. Greenwald continues to focus on game theory. She is actively involved in an international forum called Trading Agent Competition (TAC), which promotes research into the trading agent problem. In TAC Classic, a travel agent must put together a travel package for clients that includes everything the clients want (flights, hotels, etc.), but each component is sold separately in simultaneous auctions. "There's a lot of machine learning in this game," says Dr. Greenwald, "because we're trying to make predictions about what prices will be, and in particular we're trying to predict the behavior of the other agents in the game." In the newest version of the game, called TAC SCM (Supply Chain Management), agents must bid to sell their products, while at the same time getting all the components they need and predicting prices. This set of steps duplicates many of the challenges inherent in supporting effective supply chain practices.

"This is a very practical and very relevant problem, and a very, very hard one," says Dr. Greenwald. This research can be used by any company that needs to figure out its procurement schedule, as well as how it's going to put together their components, when to sell them, and what the price might be.

## Some Outcomes of KDI Projects: Project Outreach



---

Museum community improved access to software

---

New collaborations with researchers at CONABIO Mexico

---

Created online resource for science students

---



Partnership with Sun Microsystems to obtain computer system

---

Work with lawyers at the Courtroom 21 project

---

Collaboration with IBM Watson Research Center

---

Formation of alliance and development of transfer technology

---

Meeting of researchers via seminar series

---

Partnership from Pfizer as project spinoff

---

Strengthening of relationships with government community

---

Deployment of project software in the IT industry

---

Supervision of talented high school students

---

Formation of new community around project results

---

Formation of close ties with IBM and Intel

---

## Science Controversies On-line: Partnerships in Education (SCOPE)

From week to week, researchers around the world report new data pertinent to the continuing controversy over global climate change. These findings are presented in a stream of articles in the scientific press as well as the news media. Yet the stream of findings often does not reach into the nation's science classrooms, where teachers and students are saddled with stale curricula and out-of-date textbooks.

To help overcome this situation with global warming and other key issues, education researchers at the University of California at Berkeley and the University of Washington have teamed up with science journalists to develop and utilize a multidisciplinary Web site facilitating discussion of current science controversies by natural scientists, science teachers, and science learners across the country.

Other controversies dealt with by the site include genomics, genetically modified foods, the spread of malaria, and the decline of amphibian populations. The project, Science Controversies On-line: Partnerships in Education (SCOPE), was supported by a KDI grant from the National Science Foundation.

According to Professor Marcia C. Linn with the Graduate School of Education at Berkeley, one of the project's most important accomplishments was that "we were able to form partnerships between natural scientists concerned with leading-edge controversies, teachers who wanted to teach about those controversies, science journalists who were writing about those controversies, and pedagogical researchers who wanted to understand how people learned about those controversies. It really resulted, I think, in a unique research program that's enabled us to understand better how all those constituencies make sense of new information in science."

Currently, Linn says, more than 2,000 science teachers are using SCOPE materials, while the various lists for scientists involved in the online forums are "on the order of 2,000 scientists. As far as pedagogy researchers are concerned, there are a large number of research groups that have taken advantage of the materials, either to use them directly or to incorporate them into their own research projects."

Professor Linn emphasizes that the SCOPE project, by contrast with traditional science textbooks, utilizes current scientific papers and other materials available through the Internet, and thus is better able to catch the attention of students.

"With the standards movement there's a very big emphasis on the basic ideas of science, and I think unfortunately not enough attention to the contemporary scientific debates that really concern citizens," she says. "I'd love to see that changed. We found that students were extremely excited when they could research the causes of frog deformities, or the decisions concerning whether to grow genetically modified crops. And they kept coming back to their teachers year after year, to bring them new information."

Linn says the SCOPE project also has been more successful in shaping the interests of women and minority students. "I think that as far as enticing a larger number of women and minorities into scientific endeavors, these contemporary controversies are far more inviting and appealing than traditional science materials. And often [students] tell us that they're just highly motivated—they actually read newspaper articles on their own, look things up on the Internet outside of class. Which is rare, frankly, with the traditional curriculum. We think that this is a way to expand interest in science beyond the traditional groups."

Others involved with the development of SCOPE include Professor Philip Bell of the College of Education at the University of Washington and Pamela J. Hines, an editor at *Science*, a journal published by the American Association for the Advancement of Science in Washington, DC.

Bell observes that "part of our research is focused on exploring how learning technologies can uniquely support students as they learn science. This is a research endeavor for us but it's also a design endeavor because the technologies that we want to explore often don't exist yet, or they don't exist in the right form for us to be using as part of our work. So we actually go in and develop new pieces of technology for kids to use and then do research around how it goes once it's in a classroom or some other learning environment."

8.58s

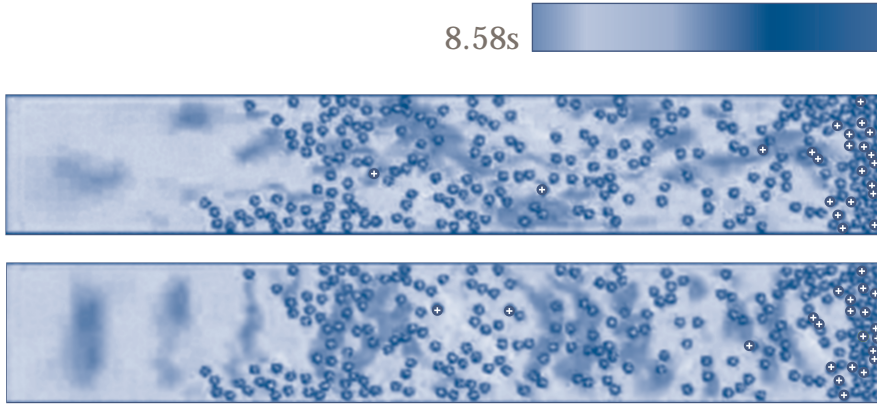

## Dispersion in Projects

The KDI projects spanned over 100 universities. Twenty-six of the research projects were geographically collocated and 36, a majority, were dispersed over as many as six institutions. Dispersion was particularly characteristic of those projects involving more disciplines (correlation  $r = .38$ ), a statistic showing that multidisciplinary projects are likely to require coordination over institutions and geographic distance.

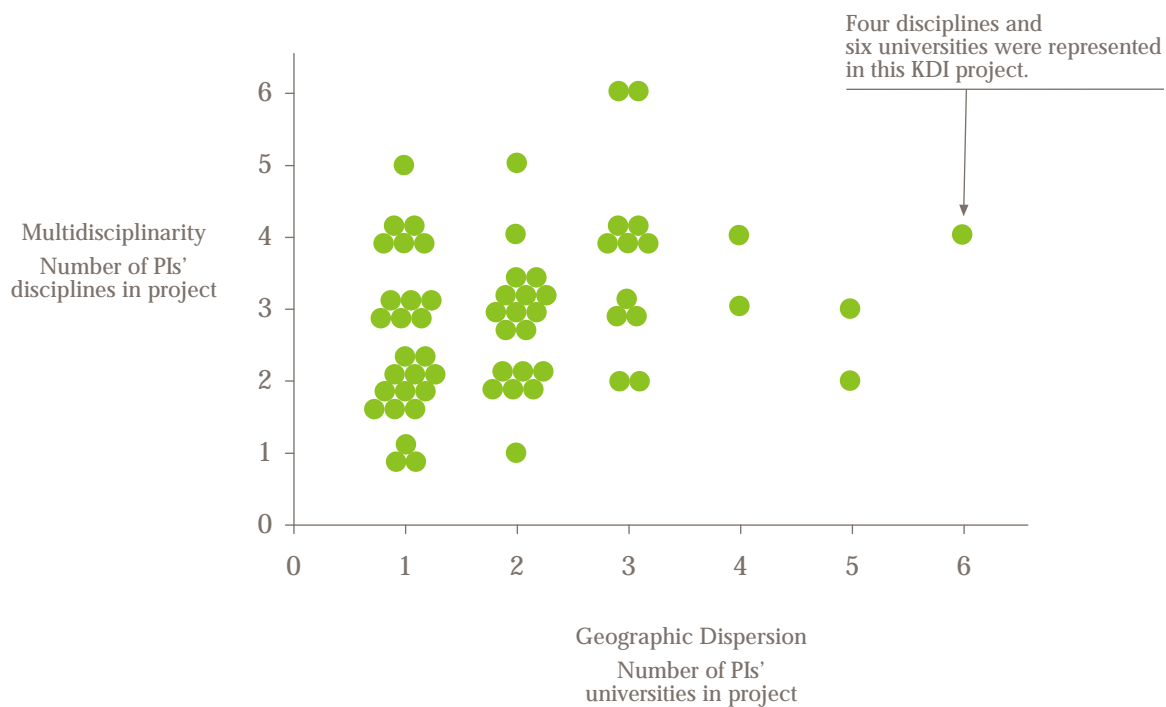



New Ideas

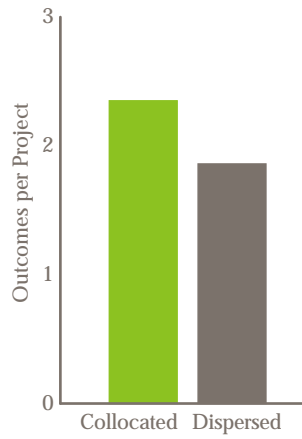

- Started new field or research area
- Came up with new spinoff projects
- Developed new methodologies
- Recognized with award



New Tools

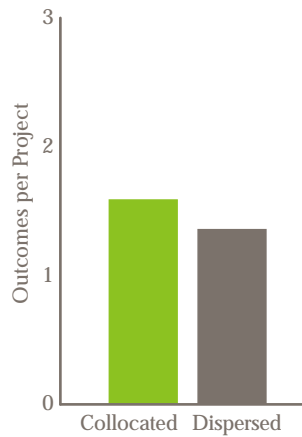

- Created new software
- Created new hardware
- Generated new datasets
- Submitted patent application



Career Development

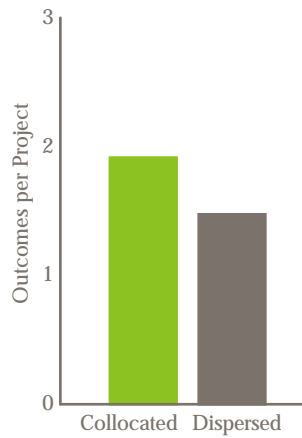

- Student finished thesis/dissertation
- Student/post-doc got academic job
- Student/post-doc got industry job



Project Outreach

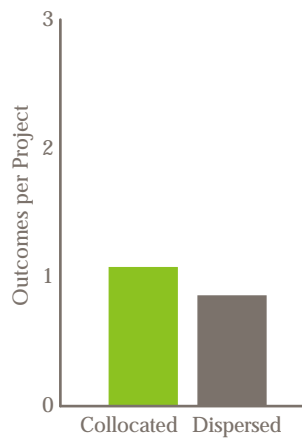

- Partnerships with industry
- Community relationships through research
- Formed collaborations with different researchers

## Outcomes in Collocated and Dispersed Projects

Although almost all KDI projects reported successful outcomes, statistical comparisons showed that projects in which the principle investigators were collocated in the same university had more successful outcomes than did projects in which principle investigators were dispersed across different universities. This difference held true even when control variables such as size of project, project budget, R & D university funding, and fields of study were used in the analysis.

The control variables and multidisciplinary had marginal overall impact in these analyses. More disciplines on a project tended to be good for the production of new ideas, new tools, and project outreach, especially when projects were collocated. More disciplines on the project tended to be less good for student training. These effects were comparatively small. The strongest statistical effects derived from dispersion. Dispersion was significantly negatively associated with the generation of new ideas and knowledge, and it was also negatively associated with student training and project outreach.

These findings are open to some alternative explanations that need to be examined further before drawing strong conclusions about all research programs. The KDI projects investigated here were a very select group and represent a mere 5-6% of all the proposals submitted in the KDI Initiative competition. The authors do not know if a selection bias operated that might have put the collocated

projects at an advantage. For example, did reviewers give special consideration to more dispersed projects because they were impressed with the number of universities represented? If collocated projects were intellectually stronger or otherwise more meritorious initially, this superiority could explain their more successful outcomes. Our analysis also represents a case study of one NSF program. This research program had a number of distinctive attributes that might have influenced the results, for example, that funding was provided for just three years, perhaps insufficient time to create effective coordination for the dispersed projects. Because of these limitations, the validity and generality of our findings comparing collocated projects with dispersed projects remains to be tested further.

# Significant Coordination Mechanisms

Percent of Projects Reporting Each Mechanism:

## I. Supervision



85%  
Supervision  
by Faculty



45%  
Supervision  
by Post-Doc



28%  
Supervision by  
Graduate Student

## II. Direct Communication



55%  
At least  
monthly in-person  
meetings



84%  
At least  
monthly phone  
calls and email

## III. Special Events



55%  
Conference  
or workshop



60%  
Seminar or  
guest speaker

## IV. Travel



52%  
Work during  
conference or  
workshop



21%  
Work during  
sabbatical leave



52%  
Travel to another  
site to work



## The Important Role of Coordination

All collaborations require coordination to integrate and link together different pieces of the project to accomplish the collective goal. KDI projects, because they were multidisciplinary collaborations, required coordination not only to connect project tasks across time, but also to enable project members to learn new methods and perspectives. A statistical analysis of coordination mechanisms employed in the KDI projects showed that a majority of projects employed time-honored approaches to coordination in scientific collaboration—direct supervision of work and project meetings and seminars, some of which included outside invited experts.

Mark Embrecht and his collaborators developed their project to explore the discovery of new pharmaceuticals through database mining. The project involved researchers from the engineering, chemistry, and mathematics departments at Rensselaer Polytechnic Institute. Though weekly group meetings were convenient because all principal investigators were based on the same campus, two who attended the KDI workshop remarked on how long it took to get the collaboration going. They estimated that it took almost a year before they were really able to make progress. Because the grant was only for 3 years, as soon as results starting coming in (e.g., their team won two data mining competitions), they had to focus on securing additional funding.

Integrating knowledge from different disciplines and learning to work together in a harmonious way required active coordination as well. A project at Arizona State University under the direction of Anshuman Razdan had the goals of developing a software library kernel, tools for data archiving, and an Internet-accessible interface to let people construct customized search engines. Because the project involved

researchers from areas such as engineering, computer science, art, and anthropology, there were no clear norms within the university for advising graduate students across departments. The international journals or conferences available for multidisciplinary research were few, and other members of the research community did not readily see the value of this research. Despite these institutional and cultural barriers to collaboration, the project kept meeting and setting goals, and successfully developed a software database that had immediate application to important problems in the biosciences, in biotechnology, and in anthropology.

Some projects also organized conferences and workshops to get project members together with one another at one site. For projects involving many universities, conferences and workshops also provided an occasion for members of the project to work together. Travel played a significant role in many projects whose members were dispersed.

Daniel Joseph's project aimed to create 3-D simulations fundamental to the chemical process for oil exploration and recovery used in industry. The project linked engineers and computer scientists from Minnesota, Texas, Pennsylvania, and Stanford. One strategy this collaboration adopted was to ask the postdoctoral fellows to learn techniques from the other discipline. For example, computer science postdocs learned about computational fluid dynamics, and computational fluid dynamics postdocs learned about computer science. Another strategy the project adopted was to hold seminars at each participating university every 6 months to evaluate progress. This multidisciplinary research led to a new field of science—direct numerical simulations for multiphase dynamics.

## Coordination in Collocated and Dispersed Projects

Collocated researchers in KDI projects found it was comparatively easy to coordinate their work on the project and to use traditional coordination mechanisms of science, such as routine lab meetings. By contrast, dispersed project researchers employed comparatively fewer coordination mechanisms overall, and those they used had to adjust to the fact of geographic distance and institutional differences.

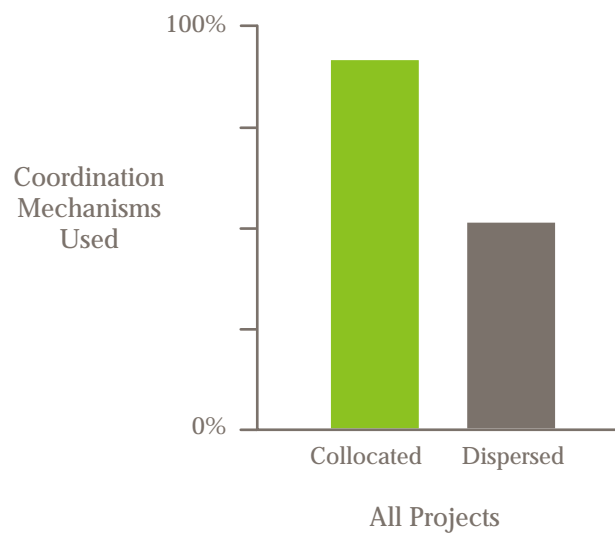

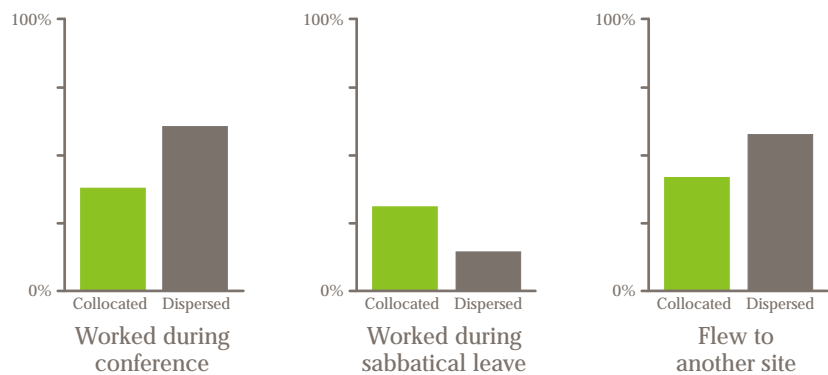
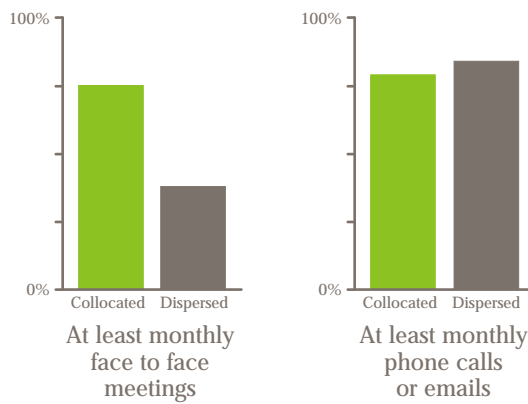
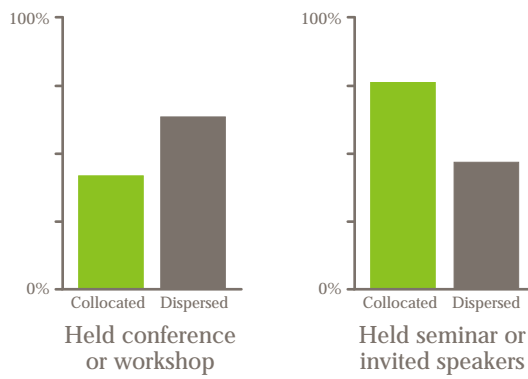
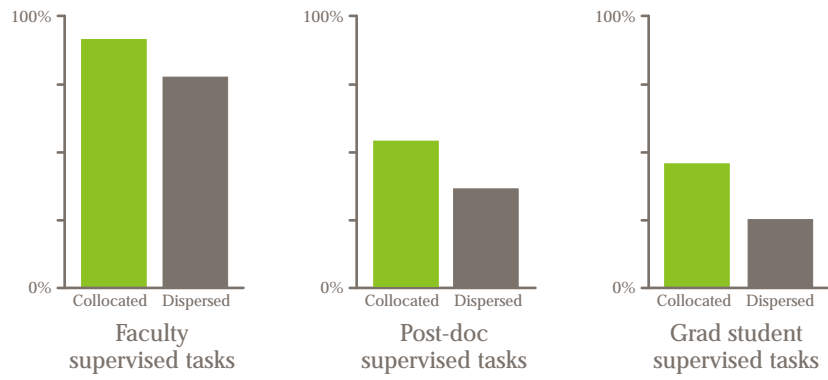

## Coordination and Outcomes

The authors used statistical regression analyses to examine the impact of coordination on project outcomes. These analyses showed that those projects that used more coordination mechanisms also had more successful outcomes. The most effective coordination mechanism, statistically, was direct supervision of project research. Face-to-face mechanisms such as holding a seminar or class, inviting outside experts to speak, and regular meetings were especially important in student training.

A comparative lack of coordination was partly responsible for the negative relationship between dispersion and project outcomes. Less coordination especially predicted fewer students trained and less project outreach.

Dispersed projects that were unable to use traditional face-to-face coordination mechanisms such as direct supervision of work and weekly lab meetings, could employ other coordination approaches, especially email, telephone, and working at conferences where principal investigators and students could converge. Those dispersed projects that employed these more effortful mechanisms were more successful than dispersed projects that did not do so. However, on average, dispersed projects did not employ sufficient coordination and were unable to catch up to collocated projects.

These analyses of KDI projects show that despite the tremendous improvements in technology for communication and sharing resources, scientists still encounter extraordinary coordination challenges when

they work across institutions. Even when dispersed projects attempted to employ both traditional and special coordination mechanisms, their efforts were insufficient, on average. These collaborations were still set back by their dispersion, and their comparative lack of success can be traced to coordination problems that comparable collaborations located at a single university did not experience.

There is good news in these results, however. First, the analyses show that multidisciplinary research can be carried out very successfully, and does not show any inherent disadvantage to unidisciplinary research. Indeed the analyses showed that multidisciplinary projects were superior to unidisciplinary projects in producing innovative new ideas and fields, and new tools for science. Second, the analyses suggest that there are steps that can be taken to improve coordination of dispersed projects, and that doing so would also increase the likelihood of success in these projects.

## Most Successful Coordination Mechanisms in Collocated Projects

Coordination Mechanism	Percent Used in Projects
Faculty supervision	92%
Phone calls or email	81%
Seminars	77%
Face to face meetings	77%
Graduate student supervision	46%

## Most Successful Coordination Mechanisms in Dispersed Projects

Coordination Mechanism	Percent Used in Projects
Phone calls or email	86%
Conference or workshop	64%
Project work during conference or workshop	61%
Air travel to another site to work	58%
Sabbatical at another project site	14%

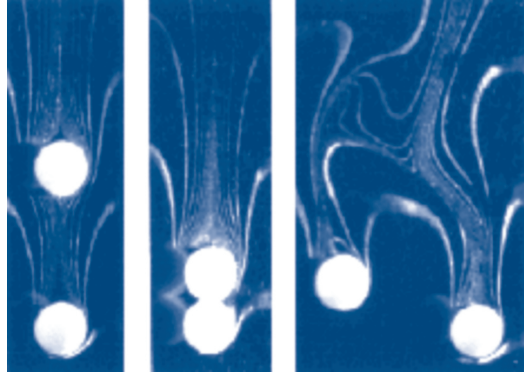

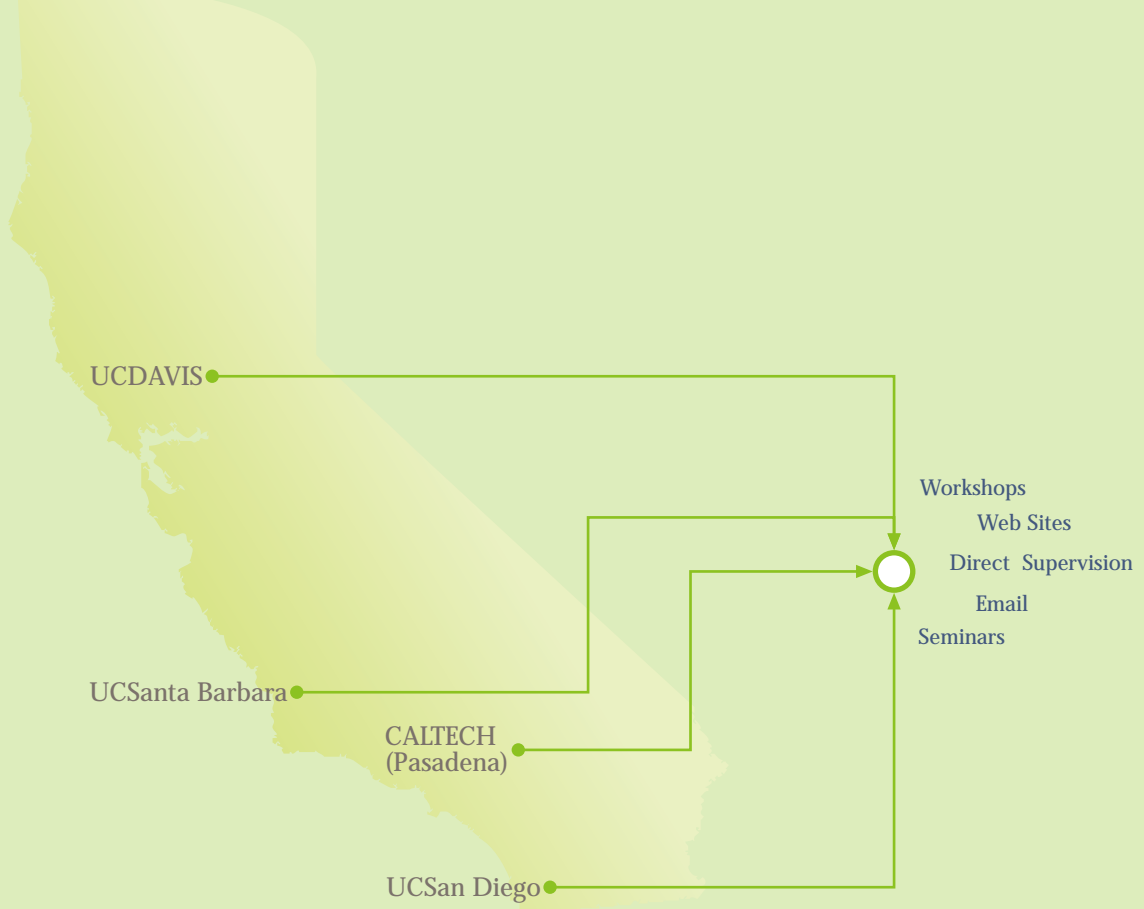

## A Successful Dispersed Project

Jerry Marsden's ambitious KDI project to advance simulations of ocean and earth systems brought together mathematicians, computer scientists, and geophysical scientists from four California universities. Marsden and his group overcame distance, bureaucracy, and everyone's busy schedules to achieve success.

One of the first steps Marsden and his collaborators did when they were awarded a special KDI grant was to schedule annual workshops, bring postdoctoral researchers onto the project, and institute a program for postdoc and student exchanges. The researchers created Web Sites to report on meetings and share papers. They created tutorial lectures, and continued communication and visits throughout the project. Postdocs helped supervise and monitor the work of students. In a workshop for KDI grantees, mathematician Steve Shkoller said these systematic steps to foster communication across the disciplines helped the mathematicians on this project identify the real needs of physical scientists, which then allowed them to develop mathematical tools.

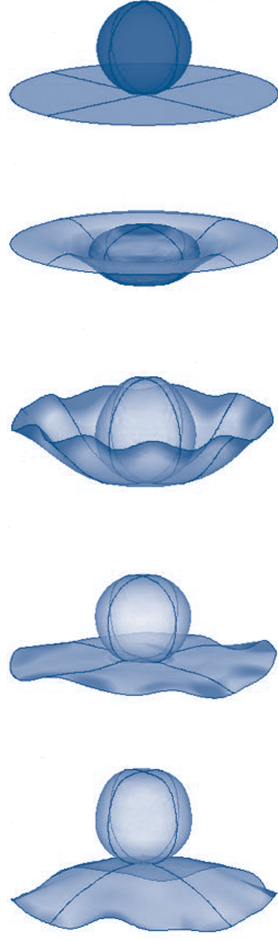



**PART THREE:  
RECOMMENDATIONS**

## Program Management for Multidisciplinary Collaboration

The findings of this evaluation study should stimulate discussion about the organization and management of multidisciplinary programs and large-scale initiatives, and the approaches that researchers themselves can use to manage multidisciplinary projects. Given the critical importance of face-to-face interaction and collocated work, which is apparent in our data as well as in the research literature, it seems evident that project-related conferences, workshops, sabbaticals, and other vehicles that support travel to other sites would improve coordination in dispersed collaborations and increase the likelihood that these projects can be successful. If researchers who are dispersed have many ongoing opportunities for direct interaction, multidisciplinary projects can reach and even exceed the outcomes of more traditional disciplinary research.

Program managers and policy makers in the research establishment already understand the difficulties of dispersed projects and often have to decide if they are willing to invest in the extra coordination costs required to make these projects successful. This decision is not easy because any investment in coordination for dispersed, multi-institutional projects can reduce funds available for other less complex projects. This study suggests that the decision should rest on the expected value of the dispersion and the commitment of project members to coordinate their work across distance. If dispersion allows for projects that bring together resources and expertise that

would not otherwise be available, then the chances for innovation should be high. On the other hand, the risk will be high also if not enough attention is paid to how these projects are managed.

What really accounts for the difficulties of dispersed projects? Are they inherently more difficult, or are they merely slower to get started, or do investigators have too little skill or time to manage distributed work arrangements? At the workshop, a litany of issues were raised about dispersion ranging from the difficulty of arranging meetings and joint courses if different universities have different teaching calendars, to the difficulty of meeting expectations of different researchers in different departments. Some university departments, feeling they were on the periphery of the problem, did not reward the investigators in dispersed projects for their work. Some projects fell apart when their budgets were cut and resources had to be redistributed. For example, in one project whose budget was cut, one of the co-PIs at a distant university was cut out of the grant entirely.

These experiences suggest a number of changes sponsors might consider to meet the challenges of dispersed collaborations. Changes have been made already in some NSF programs, such as the awarding of longer-term funding to allow investigators to build infrastructure and relationships. Principal investigators can use collaborative grant mechanisms to avoid subcontracting problems

across institutions and to provide each group with secure funds.

Other changes that could be made would be to provide budgets to support an infrastructure for dispersed collaborations and to allow principle investigator salary support for leaves or sabbaticals. These steps would permit more joint work at the same project site and increase the chances of truly collaborative work.

Other problems will be more difficult to solve. The common practice of substantially cutting the budget of a funded proposal arose for good purpose, that is, to allow support for more projects. This practice has had an unintended consequence that especially affects dispersed multidisciplinary projects. Researchers who wrote these proposals will have developed distant relationships and started joint work with others toward a research collaboration, only to have to sever or reduce their commitments to stay within the awarded budget. The costs of travel and other coordination costs (work away from the home institution, visiting colleagues, and so forth) are likely to be cut as well, even though the absence of sufficient coordination budget may mean that the collaboration is minimally collaborative. These pressures on sponsors and on researchers have unknown opportunity costs that would be worth investigating further.

## Project Management Tools

In this study, researchers' use of communication technology (email, Instant Messenger, phone conferences, and videoconferences) did not give those at multiple universities an added advantage, at least insofar as we could determine. Websites were common, though they were rarely used for ongoing work. Discussions at the workshop made clear that email, in particular, was used a great deal in KDI projects but that email failed to coordinate project work across many investigators at different places. Email sometimes encouraged too much task decomposition and too little intra-project sharing and learning. What kinds of technology might help? Our data, and comments at the workshop, suggest the requirements of such technology would include the following:

- Tools to manage and track the trajectory of tasks over time
- Tools to reduce information overload
- Tools for on-going conversation (some version of IM for busy scientists)
- Tools for awareness with reasonable interruption for spontaneous talk
- Tools to support simultaneous group decision making
- Tools to schedule presentations and to hold regular, convenient meetings across distance

## End Notes

- 1 See, for example, Chin, G., Myers, J., & Hoyt, D. 2002. Social networks in the virtual science laboratory. *Communications of the ACM* 45, no. 8: 87-92; Finholt, T., & Olson, G. 1997. From laboratories to collaboratories: A new organizational form for scientific collaboration. *Psychological Science* 8, no. 1: 28-36; Hesse, B., Sproull, L., Kiesler, S., & Walsh, J. 1993. Returns to science: Computer networks and scientific research in oceanography. *Communications of the ACM* 36, no. 8: 90-101; Schunn, C., Crowley, K., & Okada, T. 2002. What makes collaborations across a distance succeed?: The case of the cognitive science community. In P. Hinds, & Kiesler, S. (Eds.) *Distributed Work* (pp. 407-430). Cambridge, MA: MIT Press.
- 2 Allen, T. 1977. *Managing the flow of technology*. Cambridge, MA: MIT Press; Kraut, R., Egidio, C., & Galegher, J. 1990. Patterns of contact and communication in scientific research collaboration. In J. Galegher, Kraut, R., & Egidio, C. (Eds.), *Intellectual teamwork: Social and technological bases of cooperative work* (pp. 149-171). Hillsdale, NJ: Lawrence Erlbaum
- 3 Finholt, T. 2002. Collaboratories. *Annual Review of Information Science and Technology* 36: 73-107; Kouzes, R., Myers, J., & Wulf, W. 1996. Collaboratories: Doing science on the Internet. *IEEE Computer* 29, no. 8: 40-46.
- 4 Cramton, C. 2001. The mutual knowledge problem and its consequences in dispersed collaboration. *Organization Science* 12, no. 3: 346-371; Herbsleb, J., Mockus, A., Finholt, T., & Grinter, R. 2000. Distance, dependencies, and delay in a global collaboration. In *Computer-Supported Cooperative Work (CSCW)* December 1-6, 2000. Philadelphia, PA: CM; Mark, G., Grudin, J. & Poltrock, S. E. 1999. Meeting at the desktop: an empirical study of virtually collocated teams. In S. Bolker, M. King, & K. Schmidt (Eds.), *Proceedings of the Sixth European Conference on Computer Supported Cooperative Work (ECSCW)* (pp. 159-178). Dordrecht: Kluwer

## APPENDIX

## KDI Projects

### Projects and lead universities in 1998

- 1 Computational Infrastructure for Engineering Microorganisms, University of California at San Diego .
- 2 A Distributed Cognition Approach to Designing Digital Work Materials for Collaborative Workplaces, University of California at San Diego.
- 3 Structure Preserving Algorithms and Model Reduction in the Natural Sciences, California Institute of Technology .
- 4 Multidisciplinary Collaboration, Carnegie Mellon University.
- 5 Learning Complex Motor Tasks in Natural and Artificial Systems, University of California at Berkeley.
- 6 Science Controversies On-Line: Partnerships in Education (SCOPE), University of California at Berkeley.
- 7 Knowledge Networking of Biodiversity Information, University of Kansas Center for Research Inc.
- 8 Networked Engineering, Drexel University.
- 9 Computational Challenges in Cosmology, University of California at Berkeley.
- 10 Segmental and Prosodic Optical Phonetics for Human and Machine Speech Processing, House Ear Institute.
- 11 Teachable Agents: Computer Environments for Supporting High Achievement in Science and Mathematics, Vanderbilt University.
- 12 Discrete Representations in Working Memory: Developmental Neuropsychological and Computational Investigations, University of Colorado at Boulder.
- 13 Statistical Learning and Its Constraints, University of Rochester.
- 14 Computational Models and Coordinated Neuroimaging of Learning and Cognitive Function, University of Pittsburgh.
- 15 Virtual Environments and Behavior, University of California at Santa Barbara.
- 16 Molecular Information and Computer Modeling in Cardiac Electrophysiology, Allegheny University.
- 17 Global Adaptive Optimization for Structural Biology and Other Complex Signal Reconstruction Pattern Recognition and System Design Problems, Purdue University.
- 18 Next-Generation Agent-Based Distributed Simulation, Dartmouth College.

- 19 Universal Information Access: Translingual Retrieval Summarization Tracking Detection and Validation, Carnegie Mellon University.
  - 20 Scientific Communication and the Shaping of Knowledge Networks, Indiana University.
  - 21 Learning Through Writing Using Adaptive Tutoring Systems: Modeling Knowledge Representations from Open-Ended Questions, New Mexico State University.
  - 22 Artificial Implementation of Cerebro-Cerebellar Control of Reaching and Walking, Massachusetts Institute of Technology.
  - 23 Automated Learning in Network Traffic Control, New York University.
  - 24 Learning Adaptation and Layered Intelligent Systems, Massachusetts Institute of Technology.
  - 25 New Algorithms Architectures and Science for Data Mining of Massive Astrophysics Sky Surveys, Carnegie Mellon University.
  - 26 Synergistic and Decentralized Decision Making in Complex Stochastic Systems, Boston University.
  - 27 Multiscale Physics-Based Simulation of Fluid Flow for Energy and Environmental Applications, University of Texas at Austin.
  - 28 Direct Numerical Simulation and Modeling of Solid-Liquid Flows, University of Minnesota-Twin Cities.
  - 29 Multiscale Modeling of Defects in Solids, Cornell University.
  - 30 An Integrated Computational Environment for Studying Ion Movement in Biological Systems, University of Illinois at Urbana-Champaign.
  - 31 Multimodal Collaboration Across Wired and Wireless Networks, Rutgers University at New Brunswick.
  - 32 Learning of Objects and Object Classes in Visual Cortex, Massachusetts Institute of Technology.
  - 33 Sequential Decision Making in Animals and Machines, Michigan State University.
  - 34 The Effects of Representational Bias on Collaborative Learning Interactions, University of Hawaii at Manoa.
  - 35 Neuromorphic Knowledge Systems, University of Pennsylvania.
  - 36 Adaptive Sensing and Control of Large Systems Under Uncertainty with Application to Metropolitan-Area Freeways, University of California at Berkeley.
  - 37 Collaborative Knowledge Networking Environments for Team Science: Space Physics and Aeronomy Research Collaboratory (SPARC), University of Michigan.
  - 38 Towards Ideal Data Representations, University of Wisconsin at Madison.
  - 39 The Role of Experience in Language Processing, University of Illinois at Urbana-Champaign.
  - 40 Multiscale Modeling and Simulation in Scientific Inference: Hierarchical Methods for Parameter Estimation in Porous Flow, Duke University.
- Projects and lead universities in 1999**
- 41 Knowledge Networking in the Public Sector, State University of New York at Albany.
  - 42 Economic Legal and Technical Dimensions of Rights Management, University of California at Berkeley.
  - 43 Automated Design and Discovery of Novel Pharmaceuticals using Semi-Supervised Learning in Large Molecular Databases, Rensselaer Polytechnic Institute.
  - 44 A Framework for Particle Simulation from Proteins to Planetesimals, University of Washington.
  - 45 Building a Future for Software History, University of Minnesota-Twin Cities.
  - 46 An Astrophysics Simulation Collaboratory: Enabling Large Scale Simulations in Relativistic Astrophysics, Washington University.
  - 47 TalkBank: A Multimodal Database of Communicative Interaction, Carnegie Mellon University.

- 48 The Importance of Shared Visual Environments for Collaborative Tasks, Carnegie Mellon University.
- 49 Multi-scale Simulation Including Chemical Reactivity in Materials Behavior Through Integrated Computational Hierarchies, University of Florida.
- 50 Mathematical Foundations for a Networked Scientific Knowledge Base, National Institute for Standards and Technology.
- 51 Brain-Machine Interfaces for Monitoring and Modeling Sensorimotor Learning in Primates, Duke University.
- 52 Accessing Large Distributed Archives in Astronomy and Particle Physics, Johns Hopkins University.
- 53 Visualization and Spatial Reasoning: Cognitive Models Skill Acquisition and Intelligent Tutors, University of Massachusetts at Amherst.
- 54 Cross-Modal Analysis of Signal and Sense: Multimedia Corpora and Computational Tools for Gesture Speech and Gaze Research, Wright State University.
- 55 Creating a Corpus of Learning-Situated Design Guidelines & Software Components: A Foundation for Educational Software Research and Development, University of Michigan.
- 56 Coordinated Motion of Natural and Man-Made Groups, Yale University.
- 57 Temporal Abstraction in Reinforcement Learning, University of Massachusetts at Amherst.
- 58 Large-Scale Inversion-Based Modeling of Complex Earthquake Ground Motion in Sedimentary Basins, Carnegie Mellon University.
- 59 Unsteady Flows with Dynamic Boundaries: Experiment and Computation Interacting in the Virtual Environment, New York University.
- 60 A Prototype Implementation of a TeraFlop-Class Predictive Space Weather Model, Regents of University of Michigan.
- 61 The Internet Learning Forum: Fostering and Sustaining Knowledge Networking to Support A Community of Science and Mathematics Teachers, Indiana University Bloomington.
- 62 Intelligent Computational Genomic Analysis, University of Illinois at Chicago.
- 63 3D Free-Form Models for Geometric Recovery and Applications to Archaeology, Brown University.
- 64 Executing Genetic Algorithms Using DNA Genetic Materials, University of Delaware.
- 65 Simulation and Modeling of Organic and Inorganic Non-crystalline Semiconductors, Cornell University.
- 66 Co-evolution of Knowledge Networks and 21st Century Organizational Forms: Computational Modeling and Empirical Testing, University of Illinois at Urbana-Champaign.
- 67 Virtual Environments to Elucidate Strategies in Complex Spatial Problem Solving, University of California at San Francisco.
- 68 Amorphous and Crystalline Ice Growth, University of Washington.
- 69 A Knowledge Network for Biocomplexity: Building and Evaluating a Metadata-based Framework for Integrating Heterogeneous Scientific Data, University of California at Santa Barbara.
- 70 3D Knowledge: Acquisition Representation and Analysis in a Distributed Environment, Arizona State University .
- 71 Can Knowledge Be Distributed? The Dynamics of Knowledge In Interdisciplinary Alliances, University of Illinois at Urbana-Champaign.



Notes:

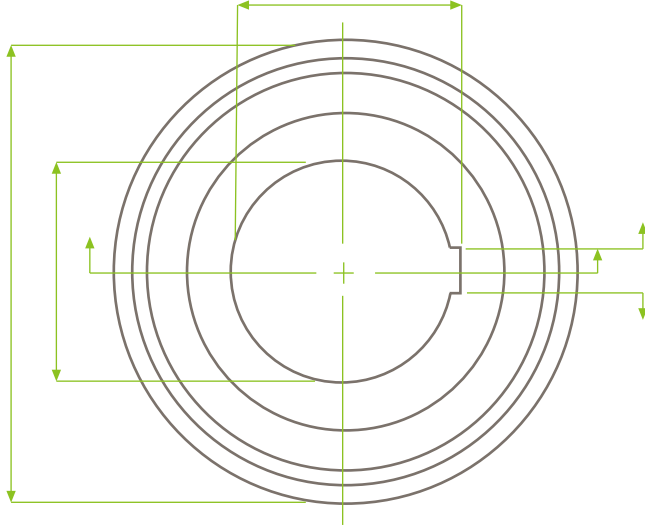



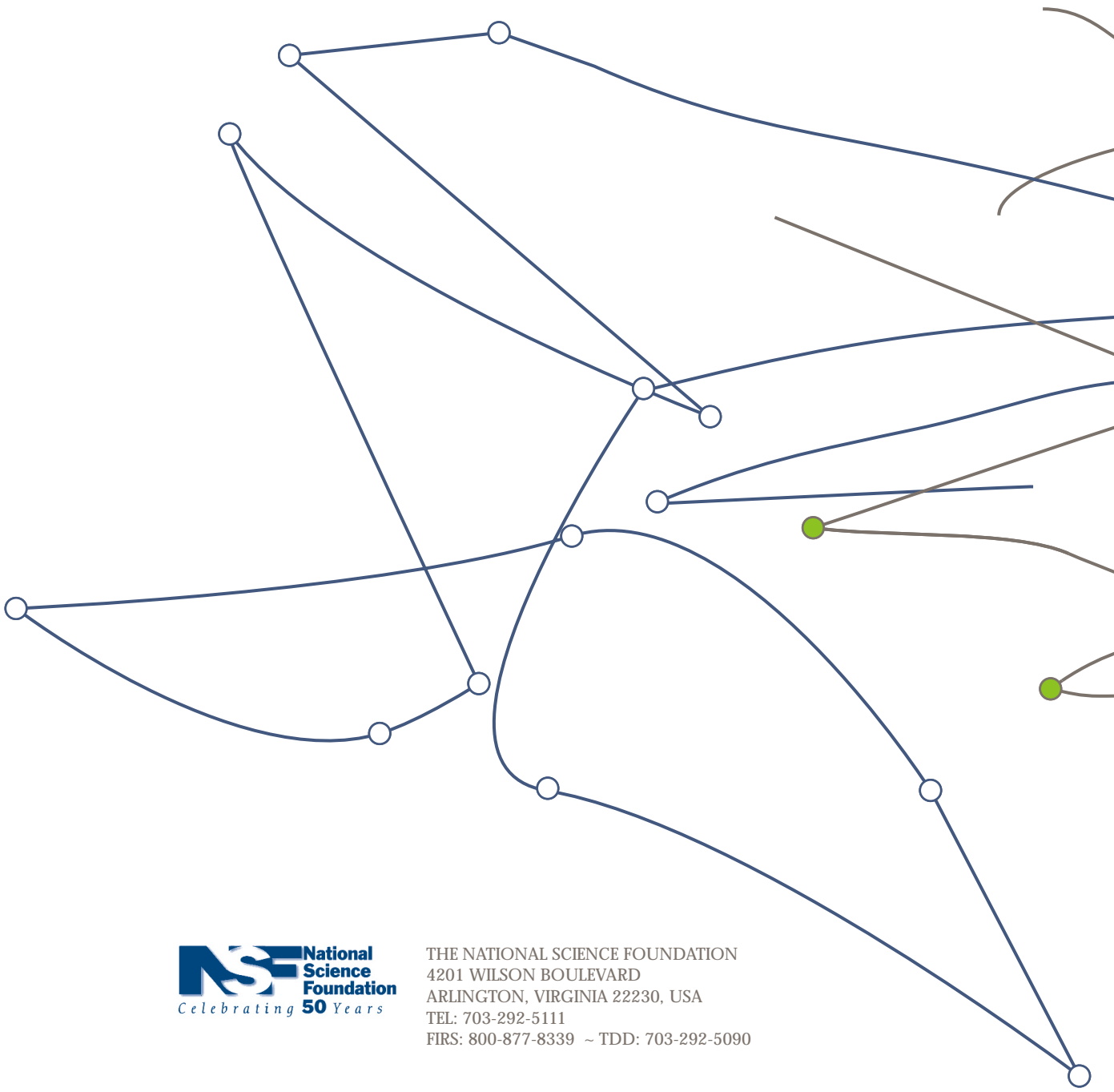

THE NATIONAL SCIENCE FOUNDATION  
4201 WILSON BOULEVARD  
ARLINGTON, VIRGINIA 22230, USA  
TEL: 703-292-5111  
FIRS: 800-877-8339 ~ TDD: 703-292-5090